

RED2S305

Owner's Manual

5 foot, Skid Steer Mounted Snow Blower

Red  Devil
Snow Blowers
Possessed to be the BEST!

270 West Park Avenue
Huron, SD 57350
866-526-5682

Serial Number: _____

Date of Purchase: _____

Red Devil Snow Blower

See Figure 1

1. The Red Devil Snow Blower will arrive on a pallet as shown.
2. In the accompanying box you will find the following:

Part Numbers	Description	Qty
RED56SH-0006	Half-Moon Chute Gear Clamps	2
RED56SH-0007	Chute Gear Ring	1
Bag of Hardware		1
Electrical Wiring Kit		1

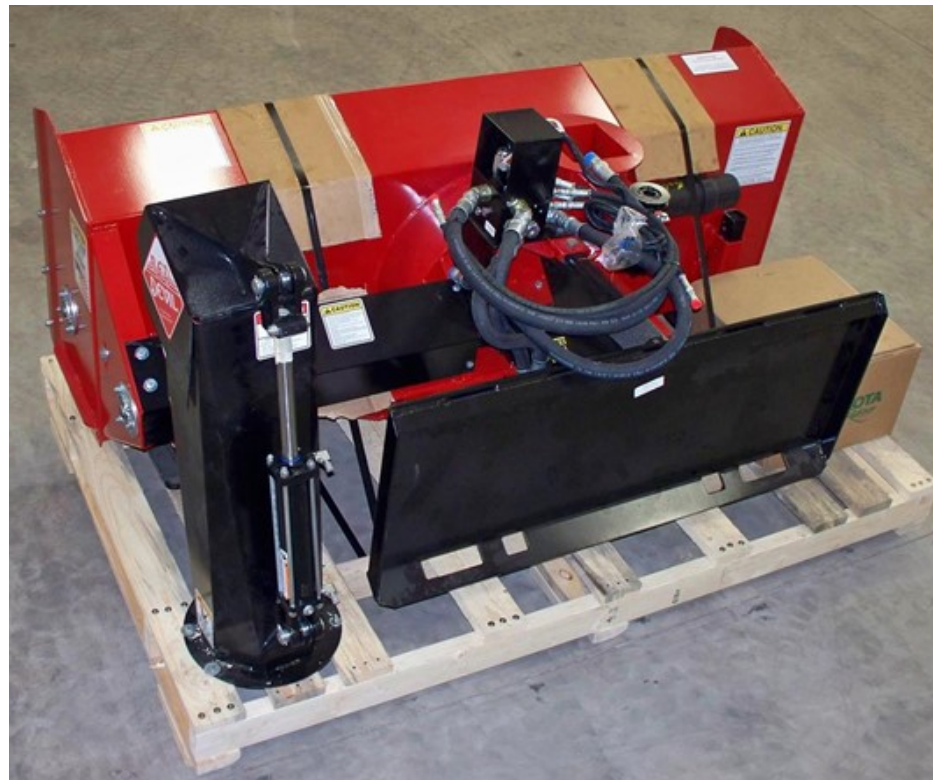
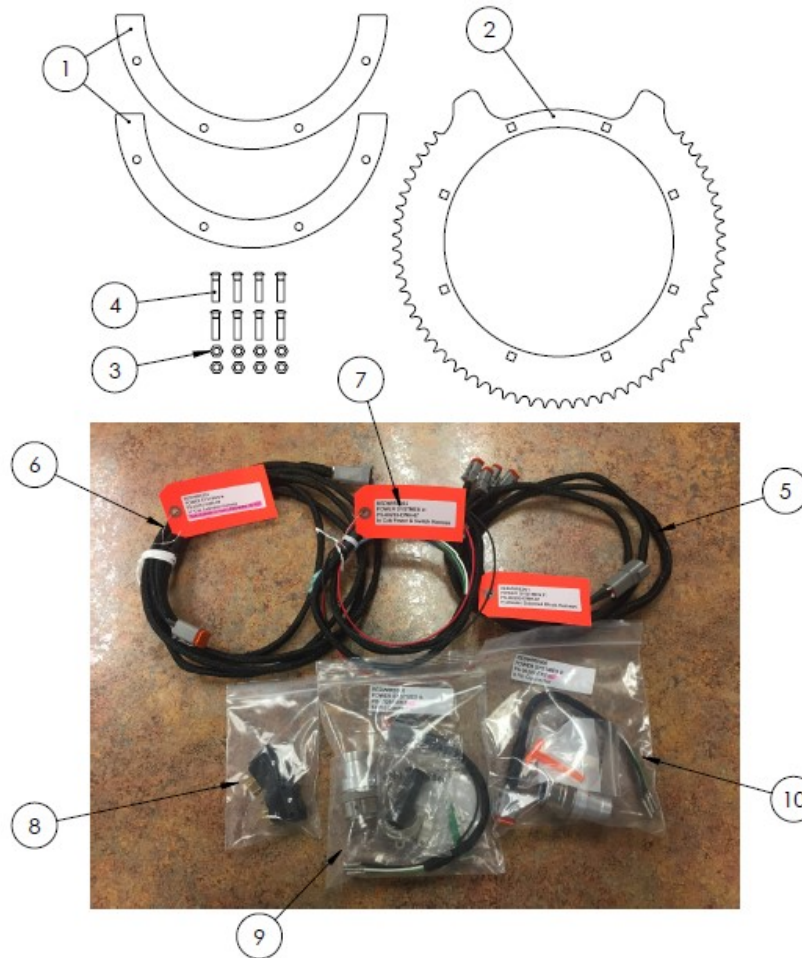

Figure 1

RED DEVIL 5' & 6' SKID STEER BOX CONTENTS

ITEM NO.	PART NUMBER	DESCRIPTION	QTY.
1	RED56SH-0006	RED DEVIL 5' & 6' CHUTE GEAR CLAMP	2
2	RED56SH-0007	RED DEVIL 5' & 6' CHUTE GEAR	1
3	REDKRJ8	5/16"-18 TOP LOCK NUT	8
4	LAN4A16A16	5/16"-18 x 1.0" CARRIAGE HEAD SCREW	8
5	REDWIRE001	HYDRAULIC SOLENOID BLOCK HARNESS	1
6	REDWIRE002	11' CAB EXTENSION HARNESS	2
7	REDWIRE003	IN CAB POWER & SWITCH HARNESS	1
8	REDWIRE004	BAG OF TWO MOMENTARY SWITCHES	1
9	REDWIRE005	14 PIN SKID STEER CONNECTOR KIT	1
10	REDWIRE006	8 PIN SKID STEER CONNECTOR KIT	1



Chute Installation

1. Slide the chute gear ring (RED56SH-0007) over the top of the impeller housing chimney as shown in figure 2. The teeth should engage with the sprocket as shown in figure 3.
2. Place the two half moon chute gear clamps (RED56SH-0006) underneath the chute gear ring.
3. Set the chute on top of the impeller housing chimney and align bolt holes of all three components as shown in figure 4.
4. Use (8) bolts (LAN4A16A16) and (8) lock nuts (REDKRJ8) to attach chute gear, half moon clamps, and chute together to complete assembly.
5. Grease the flange with the zerk installed on the bottom side of chimney flange. Rotate chute as you grease to ensure even grease distribution.
6. Tighten or loosen nuts after greasing to maintain a firm grip that will rotate easily.
7. Slide motor and gear assembly forward to make a tight fit with the chute gear and tighten bolts attaching the motor to the housing as shown in figure 5.
8. Attach hoses labeled Chute to the hydraulic cylinder.



Figure 2



Figure 3



Figure 4



Figure 5

Skid Steer Wiring Installation - Pin Connector

- In the wiring kit, there are 2 bags with similar pigtails and pin connectors: a 8-Pin and a 14-Pin. These cover most skid loader makes and models. Determine which connector your skid steer can use and set the other aside. *If yours does not have a receptacle or one that doesn't match the pin connectors provided, skip these steps and go to the Rocker Switch Installation.*
1. Either consult your skid loader owner's or use a test light to determine which pins in the skid loader connect with the switches in the cab and which pin is ground.
 2. Assemble the pin connector with what you learn. As long as the ground (black) pin is placed correct, the other 4 wires can be mixed around.



Figure 6



Figure 7



Figure 8

Skid Steer Wiring Installation - Rocker Switches

Use these instructions if the 8-Pin and 14-Pin connectors will not work on your skid loader.

The switches may be located in the provided switch plates, or in available switch knockouts in the skid steer. The below instructions show a typical skid steer installation. Location details will vary between makes and models.

1. Insert two momentary switches (REDRS1093) into the upper cab panel (Figures 9 & 10).
2. Attach the one of the short red wires from RED56WIR-4 to the middle post of a momentary switches. (The momentary switches are identical.) Then attach the blue wire and the brown wire of harness RED56WIR-3 to the same switch, one on either side of the red wire (Figure 11). This will be your chute rotation motor switch.
3. Attach the other short red wire from RED56WIR-4 to the middle post of the second momentary switch. Then attach the green wire and yellow wire of harness RED56WIR-3 to the switch, one on each side of the red wire (Figure 12). This will be your deflector control switch.
4. Connect the free end of the Red wire (RED56WIR-4) to the power wire on the skid loader and the free end of the Black wire of harness (RED56WIR-3) to a ground wire on the skid loader (Figure 13).



Figure 9



Figure 10

Skid Steer Wiring Installation - Rocker Switches

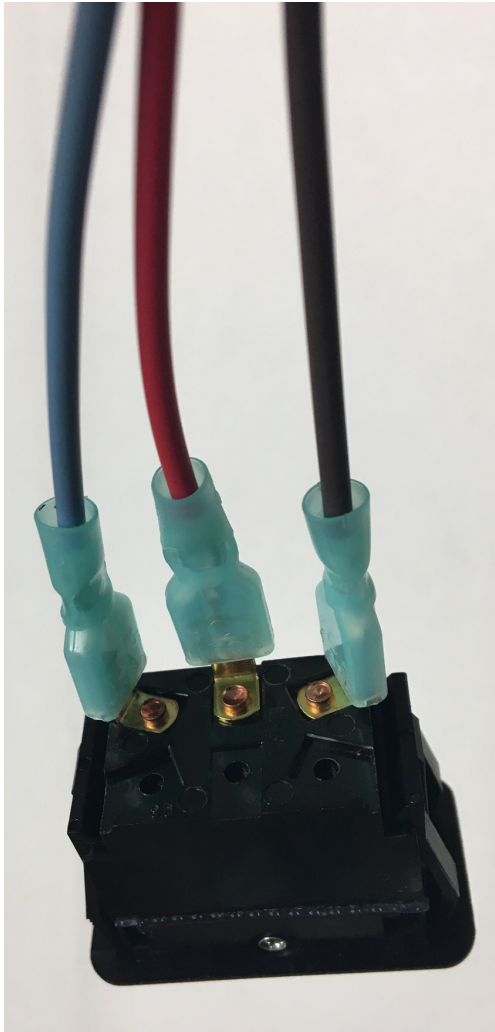

Figure 11

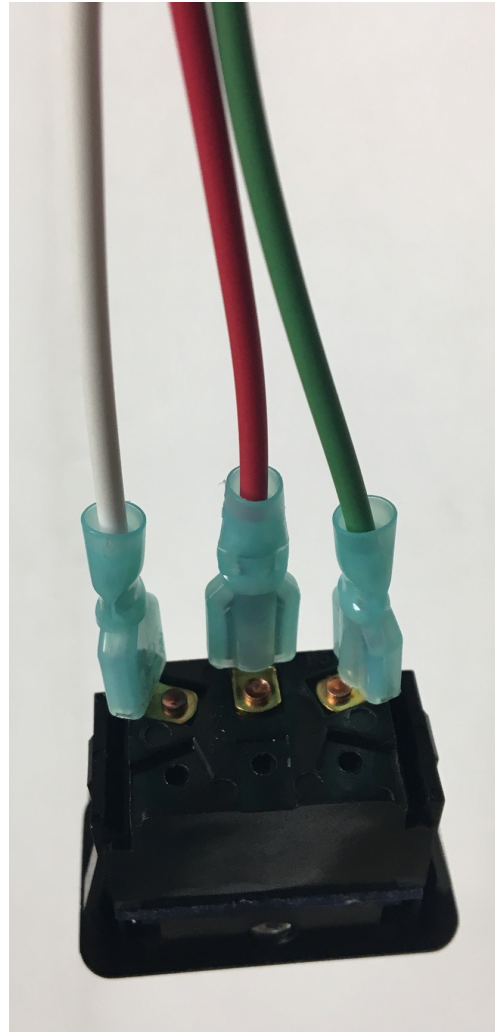
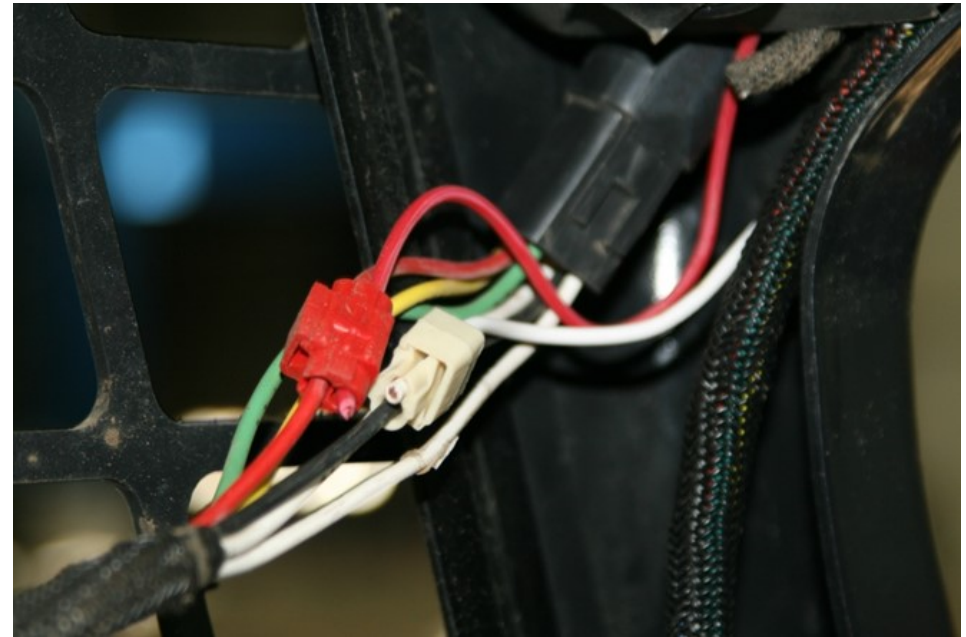

Figure 12

Figure 13



Skid Steer Wiring Installation - Solenoid Connections

1. Connect the 4 connectors shown in Figure 15 and labeled 1-4 to the solenoid receptacles in the hydraulic block of Figure 14.
2. Pair connector 1 with 2 and 3 with 4 on the solenoids.

Note: Reconfiguring which ports or solenoids the connectors mate with will depend on your preference. Switching upper and lower ports within a pair (ex. 1 & 2) will reverse the switch direction in the cab. Swapping the pairs with each other (1 & 2 with 3 & 4) will change what a switch in the cab controls (chute rotation or deflector).

3. Connect the female end of the harness to either the pin connector harness or the rocker switch harness.



Figure 14



Figure 15

Red Devil Serial Number

- A stainless steel serial number tag is located on the bracket that holds the Chute Rotation Motor.
- This serial number is required for product registration and is needed for all warranty issues (Figure 16).

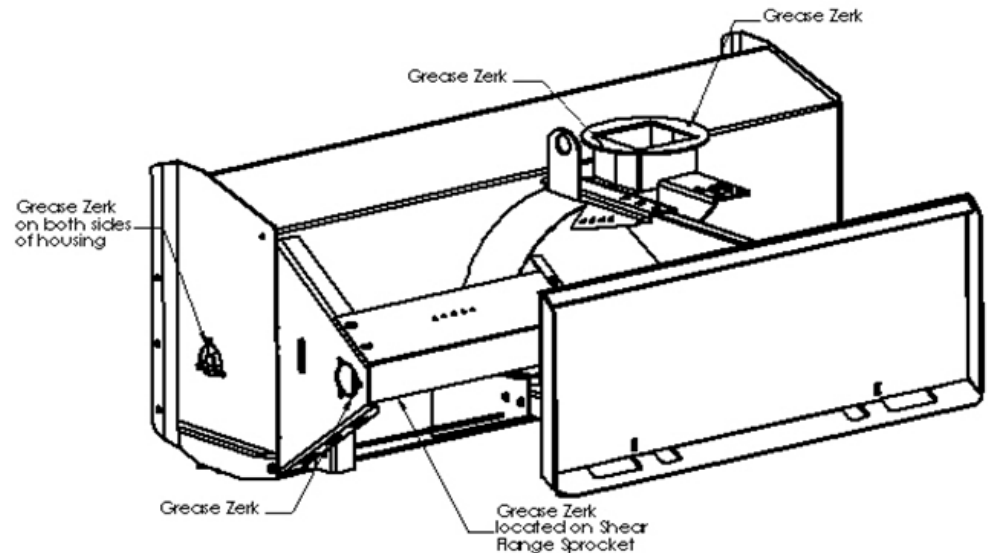

Figure 16

Preliminary Check

MAKE SURE ENGINE IS SHUT OFF AND KEYS ARE REMOVED

- ◆ Visually check the shipping pallet and packaging for any shipping damage.
- ◆ Unpack the snow blower from the shipping pallet.
- ◆ Grease all of the grease zerks on your snow blower. (See below drawing)
 - ◇ One on each end of the auger outer bearing holder.
 - ◇ One on the cross drive outer bearing holder.
 - ◇ One on the shear flange sprocket.
 - ◇ Two on chute rotation.



- ◆ Check the chain tension. Adjust idler sprocket if needed.
- ◆ Check the gear box oil level by removing the fill plug and checking for 9 ounces of oil.
- ◆ Make sure the chute rotation mechanism is working freely.
- ◆ Make sure the deflector mechanism is working freely.
- ◆ Make sure the impeller and auger are free of foreign objects.
- ◆ Make sure all decals and safety signs are clean and readable.
- ◆ Make sure all safety shields are in place and in good condition.
- ◆ Make sure all nuts, bolts, and pins are tightened and secure in place.
- ◆ Make sure the hydraulics are in good working condition by testing each function and checking for leaks.

Use Synthetic 80/90 Gear Oil In Gear Box

OPERATING THE SNOW BLOWER

- Make sure the impeller and auger are free of any loose objects.
- Check to see that all the shields and guards are in place and in good condition.
- Lubricate the snow blower before and after every use.
- After starting the engine, engage the auxiliary hydraulics.
- Ease the blower slowly into the snow.
- When clearing deep snow you may have to take more than one cut, starting at the top of the drift.
- Stop the blower's forward motion in order to assure that all snow has passed through the snow blower.
- Shallow snow can normally be cleared in one pass, depending on the density of the snow.

DO NOT BULLDOZE – THE BLOWER WAS NOT DESIGNED FOR BULLDOZING

- The most effective method of dispensing snow is to blow the snow as high as possible downwind, if room permits.
- The chute deflector will allow you to adjust the height that the snow is thrown.
- Reducing the Engine RPM will reduce the distance the snow is thrown.
- You can change the direction of the snow being thrown by using the hydraulic chute rotation controls. Always be aware of where you are throwing the snow.
- DO NOT throw the snow toward buildings, livestock, the skid steer or any other object that may be damaged.
- DO NOT change the chute direction or adjust the deflector while snow is being discharged. This may cause damage to both the chute and deflector.
- DO NOT use hydraulic controls until you check to see that the chute moves freely. Damage to chute and controls may occur.

OPERATION SAFETY

- Stop engine and remove the engine key whenever you leave the equipment seat.
- Stop engine and remove the engine key after striking a foreign object. Thoroughly inspect the blower before restarting unit.
- Stop engine and remove the engine key before attempting to service your snow blower or unplugging the impeller and chute.
- Do not rotate the chute so that discharge material will be directed toward people, your tractor, or any other object that could be damaged.
- Rotating components can catch feet, hands, and loose clothing. Stand clear of all moving parts.
- Do not climb or step on or over the snow blower for any reason.
- Never operate the snow blower in bad light or poor visibility.
- Make sure to read and understand every safety sign on your machine.
- Stay clear of the blower at all times while the hydraulics are engaged.
- Do not bulldoze. Let the machine throw the snow.
- Be aware of your surroundings and know the area you are removing the snow from.
- Do not allow anyone to ride on the snow blower at any time.
- Keep all shields in place and safety equipment intact.

Red Devil Statement of Limited Warranty

Red Devil warrants its new products to be free from defects in material and workmanship for a period of one (1) year following the date of purchase by the retail purchaser.

Red Devil warrants genuine Red Devil replacement parts and components to be free from defects in material and workmanship for a period of ninety (90) days following the date of purchase or the remainder of the original equipment warranty period, whichever is longer. Red Devil's obligation under these warranties shall be limited to repairing or replacing, free of charge to the original purchaser, any part that, in Red Devil's judgment, shows evidence of such defect

Limitations to Warranty

This warranty does not cover:

- 1) Warranty claims directly resulting from improper installation of the product.
- 2) Any product damaged by accident, abuse, misuse, or negligence after shipment from Red Devil.
- 3) Any unauthorized product alteration or modification.
- 4) Any unauthorized repairs made with parts other than genuine Red Devil parts.
- 5) Any repairs performed by anyone other than Red Devil or an authorized Red Devil dealer unless specifically authorized by Red Devil.
- 6) Snow Blower Fan Shafts.
- 7) Snow Blowers being used on a rental basis.

Warranty Procedure

Warranty registration form must be filled out and returned to Red Devil to validate all future warranty claims.

- 1) Troubleshooting should be done between end user/dealer and Red Devil through our technical assistance @ 866-526-5682.
- 2) Labor reimbursement will occur only when pre-arranged through Red Devil's technical assistance. Lankota will reimburse labor based on it's current shop rate completed within a reasonable time using Red Devil's judgment.
- 3) There is no mileage reimbursement.
- 4) Diagnostic time will not be reimbursed except in pre-arranged circumstances.
- 5) Warranty claims should be on typical dealer service work order with a number and name to be attached for any future correspondence.
- 6) All warranty work must be performed and claims submitted within thirty (30) days of the occurrence of the claim and within the warranty period.
- 7) All parts removed during warranty repair should be held for a period of thirty (30) days after the warranty claim has been submitted to Red Devil.
- 8) Red Devil reserves the right to either inspect the product at the original retail purchaser's location or require it to be returned to Red Devil for inspection.

Limitation of Liability

Red Devil makes no express warranties other than those, which are specifically described herein. Any description of the goods sold hereunder, including any reference to buyer's specifications and any descriptions in circulars and other written material published by Red Devil is for the sole purpose of identifying such goods and shall not create an express warranty that the goods shall conform to such description.

THIS WARRANTY IS EXPRESSLY IN LEU OF ALL OTHER WARRANTIES EXPRESSED OR IMPLIED. There are no warranties of merchantability or fitness of a particular purpose. This warranty states Red Devil's entire and exclusive liability and buyer's exclusive remedy or any claim for damages in connection with the sale of furnishing of Red Devil products, their design, suitability for use, installations or operation or for any claimed defects herein. RED DEVIL WILL IN NO EVENT BE LIABLE FOR ANY INCIDENTAL OR CONSEQUENTIAL DAMAGES WHATSOEVER, NOT FOR ANY SUM IN EXCESS OF THE PRICE RECEIVED FOR THE GOODS FOR WHICH LIABILITY IS CLAIMED.

No representative of Red Devil nor any dealer associated with Red Devil has the authority to change the items of this warranty in any manner whatsoever and no assistance to purchase by Red Devil in the repair of operation of any Red Devil product shall constitute a waiver of the conditions of this warranty nor shall such assistance extend or revive it.

Lankota reserves the right to make improvements in design or changes in specifications at any time, without incurring any obligation to owners of units previously sold.

Parts Book

ITEM NO.	PART NUMBER	DESCRIPTION	QTY.
1	RED56SH	RED DEVIL 5' & 6' CHUTE ASSEMBLY	1
2	RED56SS	RED DEVIL 5' & 6' QUICK TACH	1
3	RED56-SS-Powertrain	RED DEVIL SS POWERTRAIN - 5 FT	1
4	RED5H	RED DEVIL 5' HOUSING ASSEMBLY	1
5	RED5AUG	RED DEVIL 5' AUGER ASSEMBLY	1

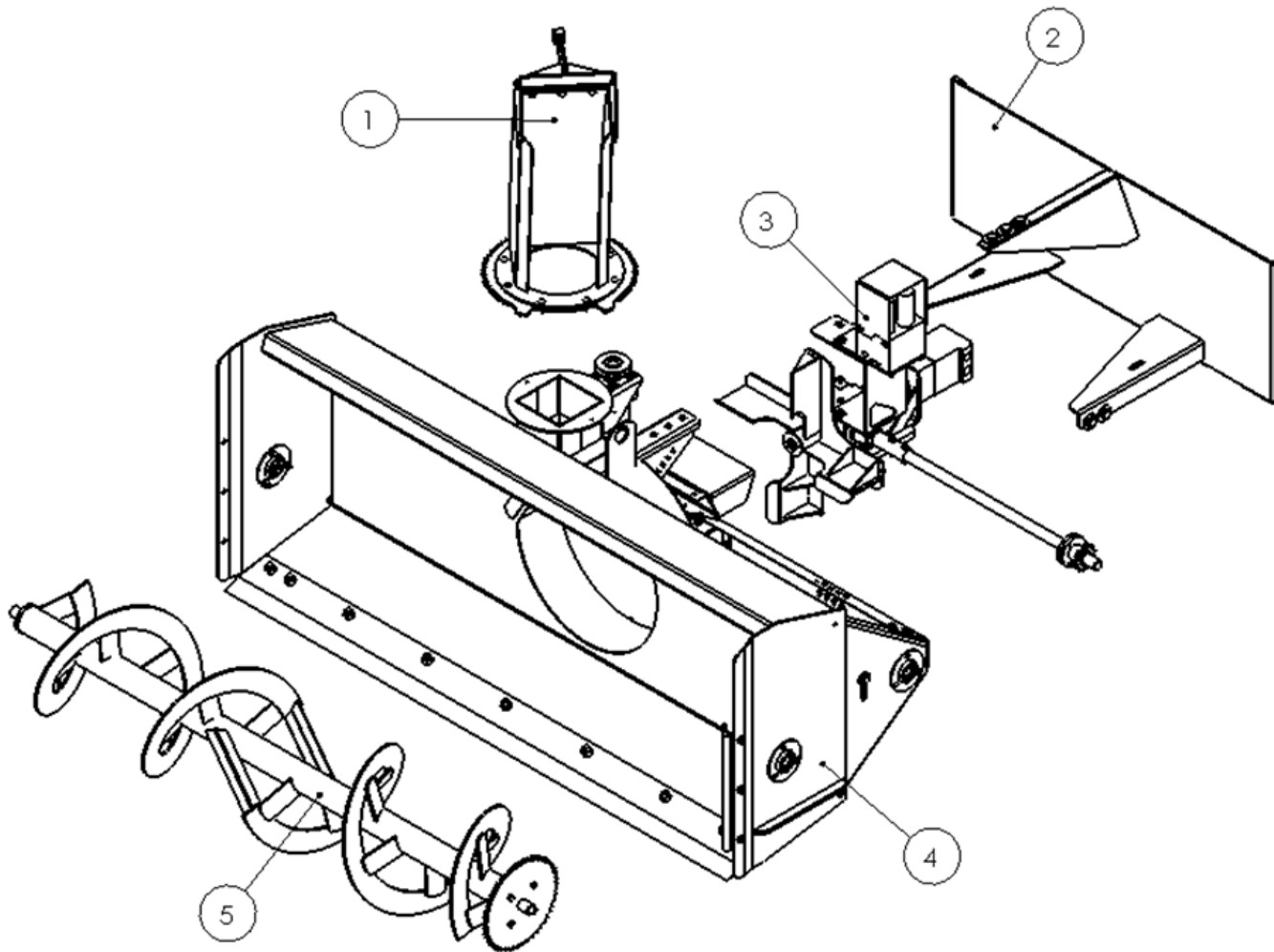

ITEM NO.	PART NUMBER	DESCRIPTION	QTY.
1	RED5H-0000	RED DEVIL 5' HOUSING COMPLETE ASSEMBLY	1
2	RED89H-SKIDS	RED DEVIL SKID SHOE WELDMENT	2
3	RED5H-0001D	RED DEVIL 5' BLOWER CUTTING EDGE	1
4	RED-44703-5	RED DEVIL 5' & 6' BLOWER SHIELD	1
5	RED56H-0034	RED DEVIL 5' & 6' BLOWER CHAIN GUARD	1
6	RED44339	RED DEVIL 5' & 6' BLOWER PTO SHIELD	1
7	RED01-315C	MANUAL HOLDER CANISTER	1
8	RED033-5017	#50 ANSI 17 Tooth Idler Sprocket	1
9	RED51677	1-1/8" BEARING ASSEMBLY	3
10	REDW742	SKID SHOE PIN	2
11	RED3234	ZERK FITTING 1/4"-28	2
12	REDE37E	1/4"-20 TOP LOCK NUT	3
13	REDB105	1/4"-20 x 1.25" HEX HEAD CAP SCREW	3
14	LANFXG26	CARRBLT - .312-18 X .75	3
15	REDB204	5/16-18 x 1.00" HEX HEAD CAP SCREW	2
16	REDKRJ8	5/16"-18 TOP LOCK NUT	5
17	LAN18000	3/8" FLAT WASHER	8
18	REDWL53	3/8" LOCK WASHER	11
19	REDNAF3	3/8" HEX NUT	7
20	LAN18A	3/8"-16 x 1" Carriage Bolt	3
21	LAN18A00	3/8"-16 x 1.00" HEX HEAD CAP SCREW	8
22	LAN22000	1/2" FLAT WASHER	14
23	RED1F30	1/2"-13 TOP LOCK NUT	1
24	REDB512	1/2"-13 x 3.00" Hex Head Cap Screw	1
25	REDKRJF	5/8"-11 TOP LOCK NUT	8
26	RED706K	CARRBLT - .625-11 X 1.5	8
27	RED10110	RED DEVIL CHUTE ROTATION MOTOR	1
28	RED51039	RED DEVIL CHUTE ROTATION SPROCKET	1

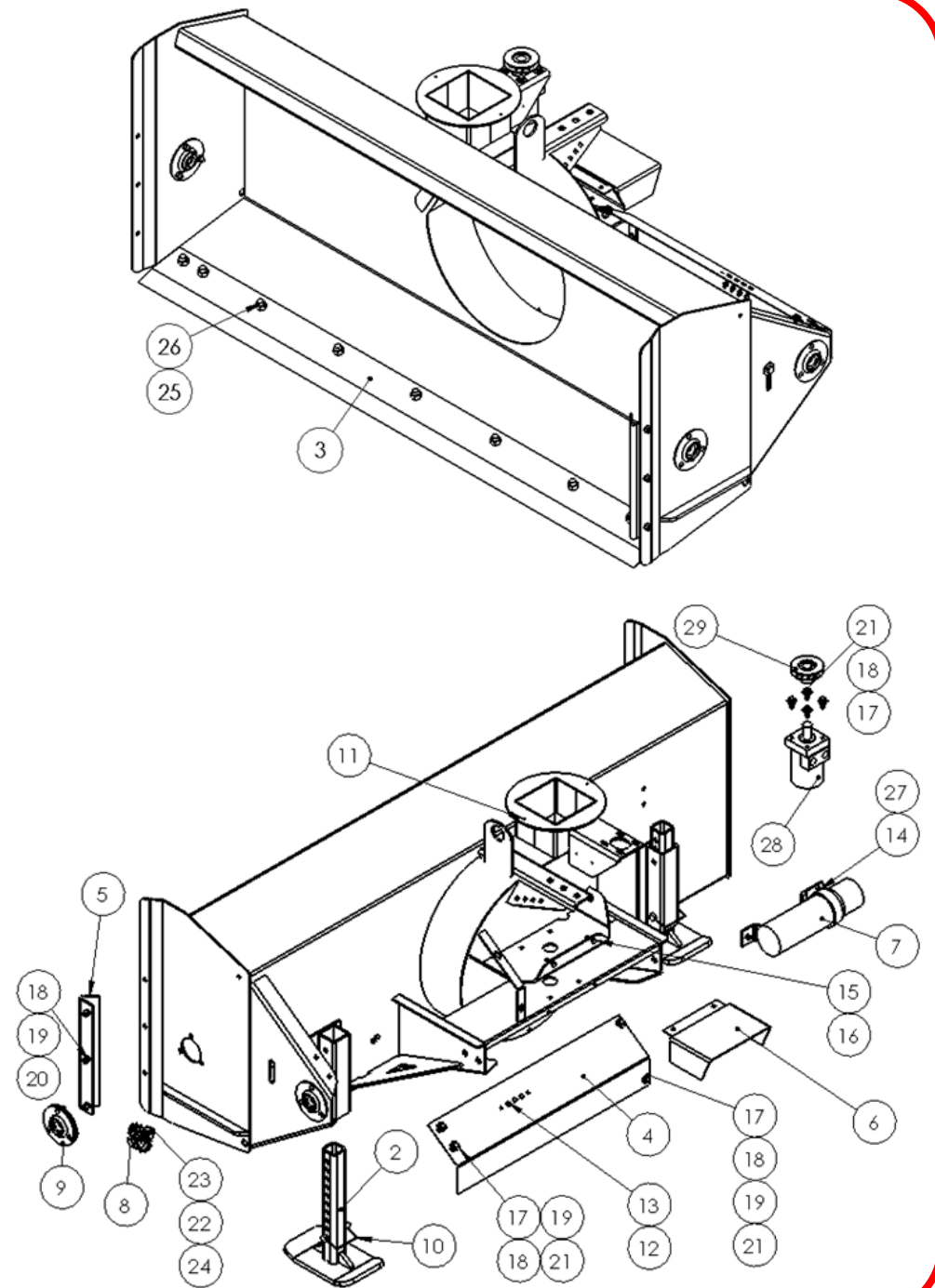

ITEM NO.	PART NUMBER	DESCRIPTION	QTY.
1	RED39200	RED DEVIL 5' & 6' SKID STEER MOUNT	1
2	REDB706	5/8"-11 x 1.50" HEX HEAD CAP SCREW	7
3	LAN26000	5/8" FLAT WASHER	7
4	REDKRJF	5/8"-11 TOP LOCK NUT	7

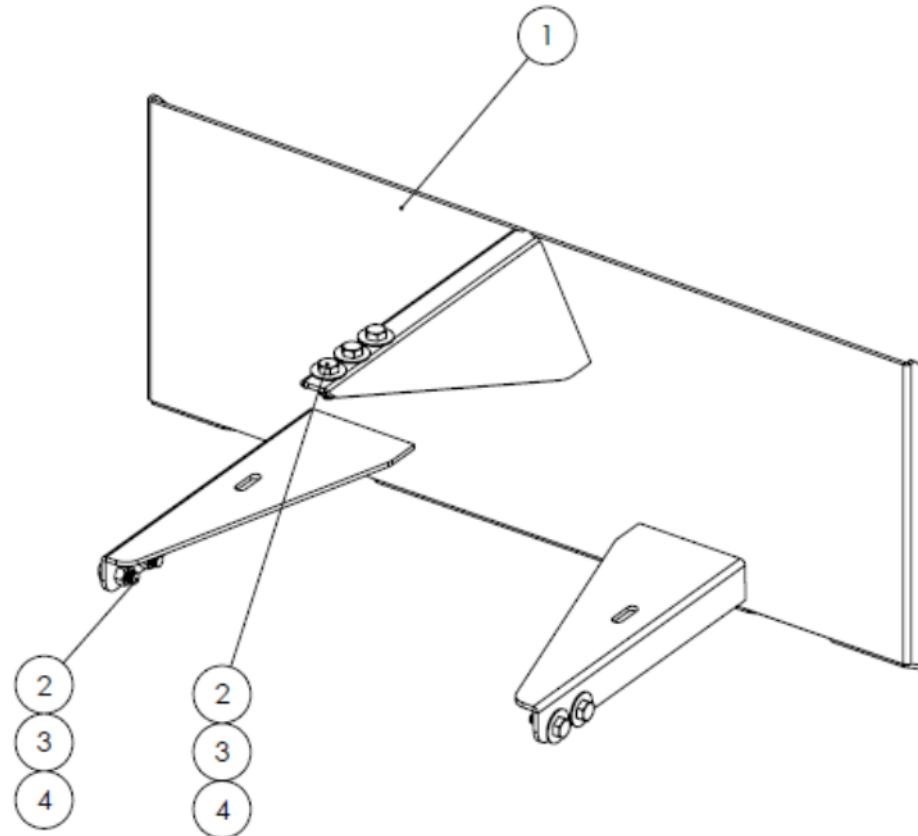

ITEM NO.	PART NUMBER	DESCRIPTION	QTY.
1	RED10027	RED DEVIL 5' & 6' GEAR BOX	1
2	RED10913B	RED DEVIL SKID STEER HYDRAULIC MOTOR	1
3	REDHB25	RED DEVIL STD FLOW HYDRAULIC BLOCK	1
4	RED56IMP	RED DEVIL 5' & 6' IMPELLER WELDMENT	1
5	RED5SE	RED DEVIL SHEAR FLANGE ASSY - 5 FT	1
6	RED36536	RED DEVIL 5' & 6' SHEAR FLANGE COUPLER	1
7	RED11005	RED DEVIL SKID STEER MOTOR MOUNT	1
8	RED11006A	RED DEVIL 1/2" MOTOR MOUNT SHIM	1
9	RED11006B	RED DEVIL 3/8" MOTOR MOUNT SHIM	1
10	RED56H-0022	RED DEVIL HYDRAULIC BLOCK MOUNT	1
11	RED56H-0124N	RED DEVIL HYDRAULIC BLOCK SHIM	1
12	RED56SS-C1	SPROCKET COUPLER 1.0" BORE 16T 50#	1
13	RED56SS-C2	SPROCKET COUPLER 1.25" BORE 16T 50#	1
14	RED56SS-C3	CHAIN FOR SPROCKET COUPLER 16T 50#	1
15	RED10BH	MACHINE KEY 1/4" X 2.00"	1
16	RED167V	MACHINE KEY 1/4" X 1.75"	2
17	REDB308	3/8"-16 x 2.00" HEX HEAD CAP SCREW	6
18	LAN18A00	3/8"-16 x 1.00" HEX HEAD CAP SCREW	11
19	LAN18000	3/8" FLAT WASHER	9
20	RED0F23	3/8" FENDER WASHER	1
21	REDWL53	3/8" LOCK WASHER	15
22	REDNAF3	3/8" HEX NUT	2
23	RED0DTT	3/8"-16 TOP LOCK NUT	2
24	LAN22A32	HHCS - .5-13 X 1.5, GR. 5	2
25	LAN22000	1/2" FLAT WASHER	2
26	RED1F30	TOP LOCK NUT - .5-13, GR. 5	2
NA	REDHB25-HK	HOSE KIT FOR BLOCK/MOTOR/SKID	1
NA	RED50RC	ANSI 50 ROLLER CHAIN - 90 LINK	1
NA	RED50OL	OFFSET LINK FOR ANSI 50 ROLLER CHAIN	1
NA	RED50CL	CONNECTOR LINK FOR ANSI 50 CHAIN	1

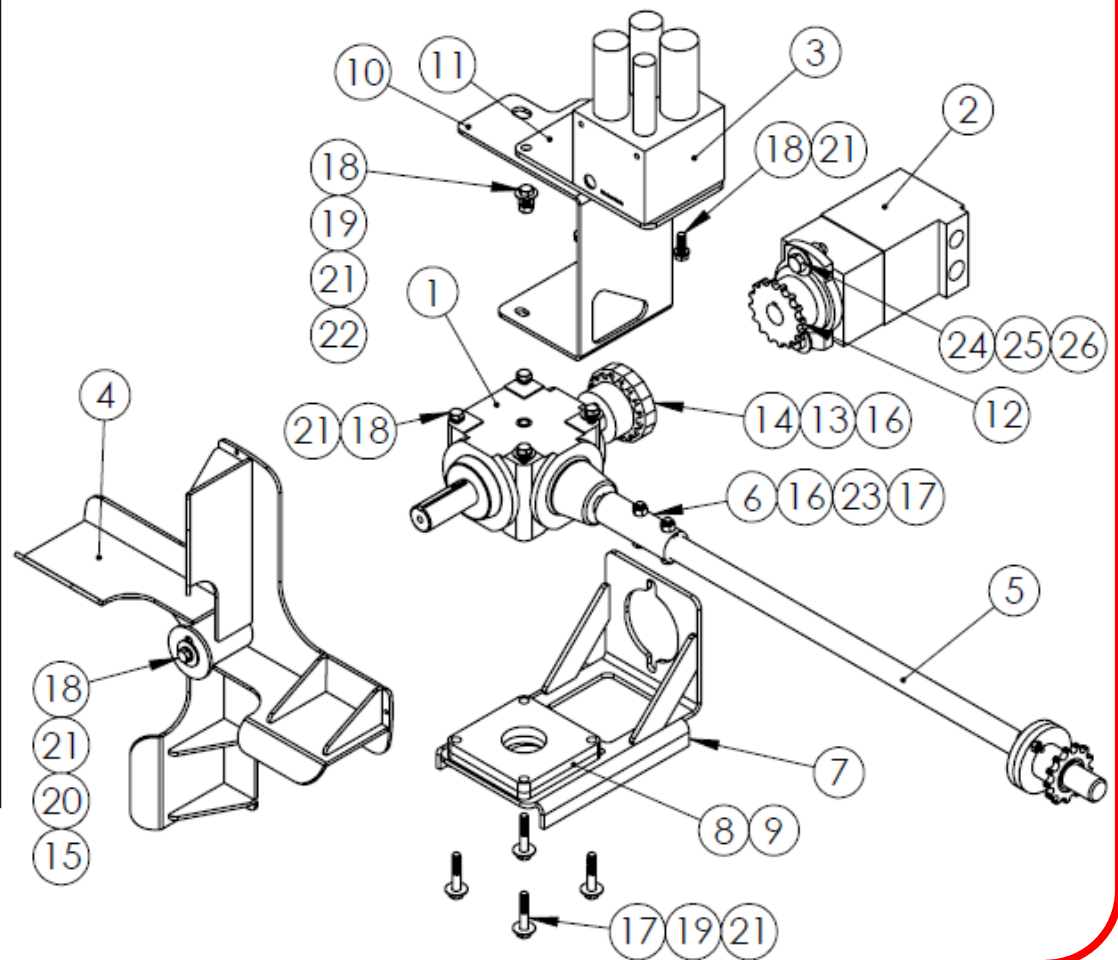

ITEM NO.	PART NUMBER	DESCRIPTION	QTY.
1	RED5AUG-0000	RED DEVIL 5' AUGER WELDMENT	1
2	RED36525	50T 50# CHAIN SPROCKET	1
3	REDB306	3/8"-16 x 1.50" HEX HEAD CAP SCREW	4
4	REDODTT	3/8"-16 TOP LOCK NUT	4

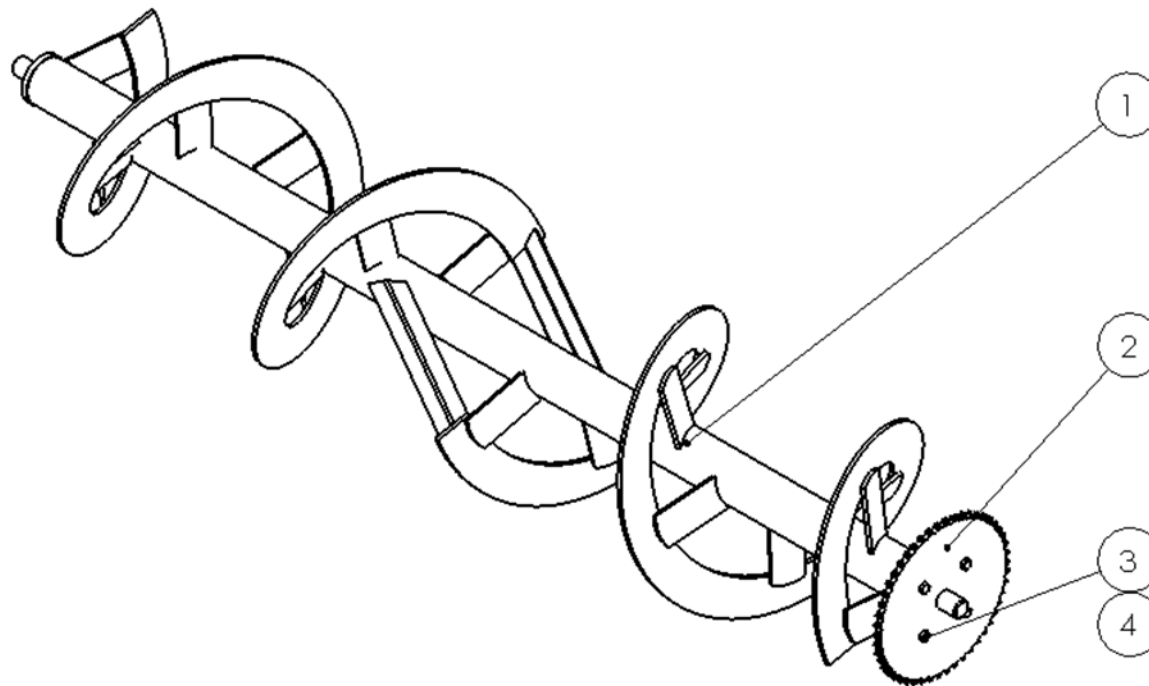

ITEM NO.	PART NUMBER	DESCRIPTION	QTY.
1	RED56SH-000C	RED DEVIL 5' & 6' CHUTE WELDMENT	1
2	RED56SH-000D	RED DEVIL 5' & 6' DEFLECTOR WELDMENT	1
3	RED56SH-0006	RED DEVIL 5' & 6' CHUTE GEAR CLAMP	2
4	RED56SH-0007	RED DEVIL 5' & 6' CHUTE GEAR	1
5	RED2010111	2X8 DEFLECTOR CYLINDER	1
6	REDKRJ8	5/16"-18 TOP LOCK NUT	8
7	LAN4A16A16	5/16"-18 x .75" CARRIAGE SCREW	8
8	RED0DTT	3/8"-16 TOP LOCK NUT	3
9	LAN18A	3/8"-16 x 1" CARRIAGE SCREW	3

