

**RED23508**

**Owner's Manual**

8 foot, 3-Point Mounted Snow Blower

Red  Devil  
Snow Blowers  
*Possessed to be the BEST!*

**270 West Park Avenue**

**Huron, SD 57350**

**866-526-5682**

**Serial Number:** \_\_\_\_\_ **Date of Purchase:** \_\_\_\_\_

# Red Devil Snow Blower

See Figure 1.

1. The Red Devil Snow Blower will arrive on a pallet as shown in Figure 1.
2. In the accompanying box you will find the following:

<b><i>Part Numbers</i></b>	<b><i>Description</i></b>	<b><i>Quantity</i></b>
RED89SH-0005	Half Moon Rotation Gears	2
RED89SH-0004	Half Moon Chute Gear Clamps	2
Bag of Hardware		1

Figure 1



## RED89CGK3P KIT

ITEM NO.	PART NUMBER	DESCRIPTION	QTY.
1	RED89SH-0004	RED DEVIL 8' & 9' CHUTE GEAR CLAMP	2
2	RED89SH-0005	RED DEVIL 8' & 9' CHUTE GEAR	2
3	RED305K	3/8" X 1-1/2" CARRAIGE BOLT	12
4	REDODTT	3/8"-16 TOP LOCK NUT	12

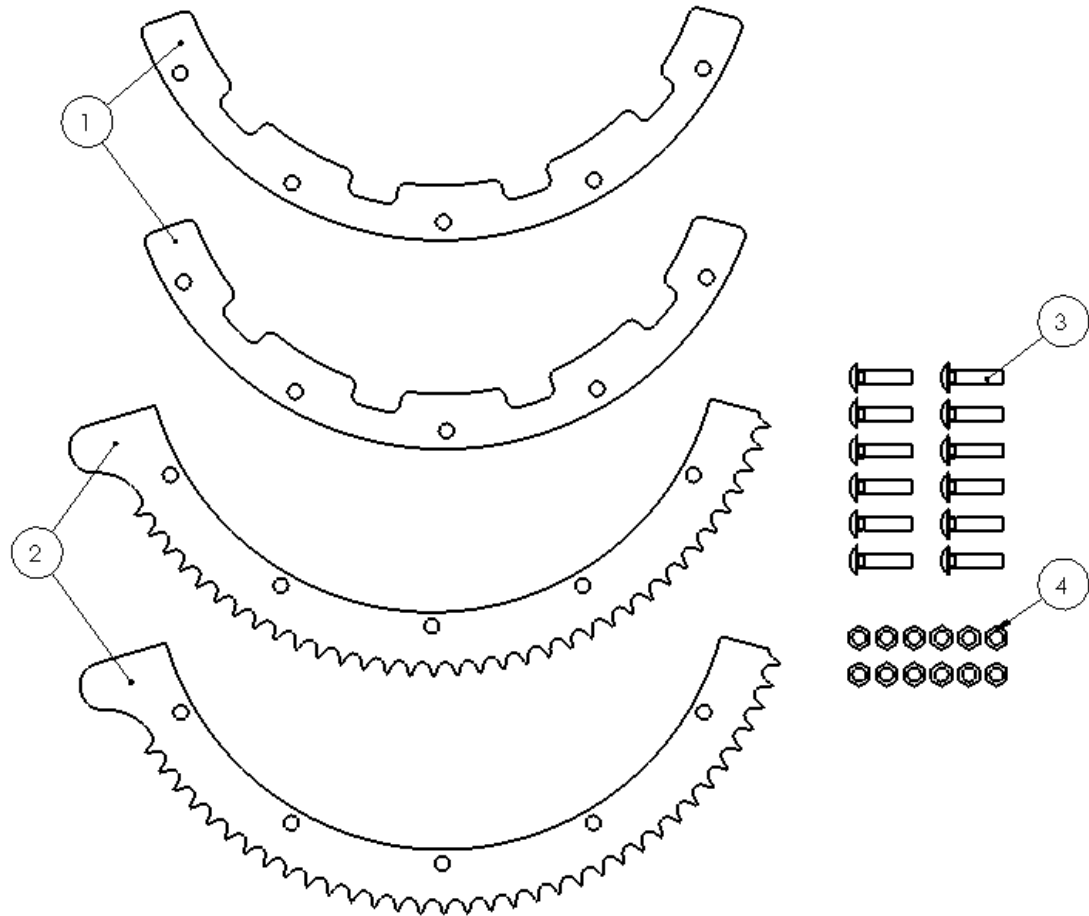

# Chute Installation

1. Place and center the chute on the impeller housing flange as shown in Figure 2.
2. Slide one of the chute gears (RED89SH-0005) underneath the chute so that it engages with the hydraulic rotation motor as shown in Figure 3
3. Place one chute gear clamp (RED89H-0004) under the chute gear, align all holes, and attach using the 3/8" carriage bolts and 3/8" lock nuts. (See Figure 4). Verify that the chute gear is clamped directly to the chute and not the impeller housing flange.
4. Repeat steps 2 & 3 on the other side of the chute.
5. Grease the flange with the zerk installed on the bottom side of chimney flange. Rotate chute as you grease to ensure even grease distribution.
6. Tighten or loosen nuts after greasing to maintain a firm grip that will rotate easily.
7. Slide motor and gear assembly forward to make a tight fit with the chute gear and tighten bolts attaching the motor to the housing as shown in figure 5.



Figure 2



Figure 3



Figure 4



Figure 5

# Red Devil Serial Number

1. A stainless steel serial number tag is located on the bracket that holds the Chute Rotation Motor.
2. This serial number is required for product registration and is needed for all warranty issues. (As shown in Figure 8)

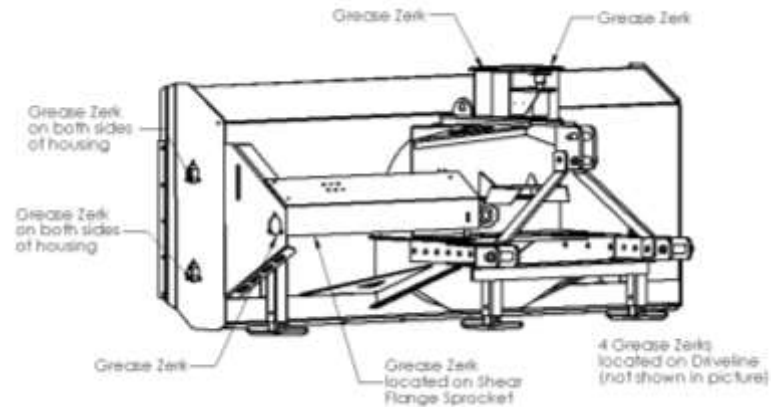

Figure 8

## Preliminary Check

### **MAKE SURE PTO IS DISENGAGED, ENGINE IS SHUT OFF AND KEYS ARE REMOVED**

- ✓ Visually check the shipping pallet and packaging for any shipping damage.
- ✓ Unpack the snow blower from the shipping pallet.
- ✓ Grease all of the grease zerks on your snow blower. (See below drawing)
  - One on each end of the auger outer bearing holder.
  - One on the cross drive outer bearing holder.
  - One on the shear flange sprocket.
  - Two on chute rotation.
  - Four on the driveline



- ✓ Check the chain tension. Adjust idler sprocket if needed.
- ✓ Check the gear box oil level by removing the fill plug and checking for 9 ounces of oil.
- ✓ Make sure the chute rotation mechanism is working freely.
- ✓ Make sure the deflector mechanism is working freely.
- ✓ Make sure the impeller and auger are free of foreign objects.
- ✓ Make sure all decals and safety signs are clean and readable.
- ✓ Make sure all safety shields are in place and in good condition.
- ✓ Make sure driveline shield spins freely.
- ✓ Make sure the drive line is the proper length for your 3-Point setup.
- ✓ Make sure all nuts, bolts, and pins are tightened and secure in place.
- ✓ Make sure the hydraulics are in good working condition by testing each function and checking for leaks.

## **Use Synthetic 80/90 Gear Oil In Gear Box**

## **OPERATING THE SNOW BLOWER**

- Make sure the impeller and auger are free of any loose objects.
- Check to see that all the shields and guards are in place and in good condition.
- Lubricate the snow blower before and after every use.
- After starting the engine, engage the PTO.
- Ease the blower slowly into the snow.
- When clearing deep snow you may have to take more than one cut, starting at the top of the drift. Remember to disengage the PTO when raising the snow blower.
- Stop the blower's motion and allow all snow to pass through the snow blower before turning off.
- Shallow snow can normally be cleared in one pass, depending on the density of the snow and the available horsepower.

### **DO NOT BULLDOZE – THE BLOWER WAS NOT DESIGNED FOR BULLDOZING**

#### **DESIGNED FOR 540 RPM ONLY**

- The most effective method of dispensing snow is to blow the snow as high as possible downwind, if room permits.
- The chute deflector will allow you to adjust the height that the snow is thrown.
- Reducing the PTO RPM will reduce the distance the snow is thrown.
- You can change the direction of the snow being thrown by using the hydraulic chute rotation controls. Always be aware of where you are throwing the snow.
- Your snow blower has Manual deflector control.
- DO NOT throw the snow toward buildings, livestock, the tractor or any other object that may be damaged.
- DO NOT change the chute direction or adjust the deflector while snow is being discharged. This may cause damage to both the chute and deflector.
- DO NOT use hydraulic controls until you insure that the chute moves freely. Damage to chute and controls may occur.

### **OPERATION SAFETY**

- Disengage PTO, stop engine, and remove the engine key whenever you leave the equipment seat.
- Disengage PTO, stop engine, and remove the engine key after striking a foreign object. Thoroughly inspect the blower before restarting unit.
- Disengage PTO, stop engine, and remove the engine key before attempting to service your snow blower or unplugging the impeller and chute.
- Do not rotate the chute so that discharge material will be directed toward people, your tractor, or any other object that could be damaged.
- Rotating components can catch feet, hands, and loose clothing. Stand clear of all moving parts.
- Do not climb or step on or over the snow blower for any reason.
- Never operate the snow blower in bad light or poor visibility.
- Disengage the PTO while raising, lowering, and transporting the snow blower.
- Make sure to read and understand every safety sign on your machine.
- Stay clear of the blower at all times while the PTO is engaged.

- Do not bulldoze. Let the machine throw the snow.
- Be aware of your surroundings and know the area you are removing the snow from.
- Do not allow anyone to ride on the snow blower at any time.
- Keep all shields in place and safety equipment intact.

# **DRIVELINE INSTALLATION INSTRUCTIONS**

## **FOLLOW INSTRUCTIONS CAREFULLY TO DETERMINE THE PROPER FIT OF THE DRIVELINE**

1. Hook up snow blower to lower arms of the 3-point.
2. Measure the distance from the end of the PTO shaft to the end of the gear box shaft
3. Lay driveline on flat surface and measure the distance from one yoke to the other in the most retracted position. If the driveline length is greater than length of shaft, move the mountings to correct the length, shorten driveline or use a CAT II quick hitch.
4. If distance from shaft to shaft is greater than 9" more than the overall length of driveline, it may be too short. Most drivelines require a minimum of 5" overlap.
5. Once the driveline is installed, slowly lift the snow blower through the complete arc of 3-point mount. Make sure driveline does not bottom out anywhere throughout the arc. Make sure the shields do not separate.



# Driveline Safety and Maintenance

- Keep driveline shield in place – do not remove. Never operate your snow blower when driveline shields are damaged or missing. These shields have been installed for your safety. Personal injury or even death can result from entanglement in rotating components.
- Do not operate your snow blower with a driveline that is too long or with a dented shield. This will not allow the shaft to telescope freely. Operating under these conditions can cause damage to the snow blower, gear box, driveline knuckles, or your tractor.
- Keep the driveline well greased or oiled. (Oil should be used in severe cold)
- Make sure the third arm on the tractor 3-point will have the snow blower sitting level and resting on the skid shoes. This will keep the knuckles on the driveline running as straight as possible.
- Raising and lowering the snow blower while the PTO is engaged can cause severe damage to the driveline and the tractor.
- This driveline is designed to operate at 540 rpm only.
- Operating the driveline at an excessive angle will shorten the life of the driveline.
- Personal injury or even death can result from entanglement with drivelines. Stay clear of driveline at all times while PTO is engaged.
- If your driveline is making a chattering noise you may be running at too steep of an angle. You may need to move the mounting out to lessen the angle.
- Drivelines must always have at least 5” of overlap.
- Grease before operating your snow blower.

# Red Devil Statement of Limited Warranty

Red Devil warrants its new products to be free from defects in material and workmanship for a period of one (1) year following the date of purchase by the retail purchaser.

Red Devil warrants genuine Red Devil replacement parts and components to be free from defects in material and workmanship for a period of ninety (90) days following the date of purchase or the remainder of the original equipment warranty period, whichever is longer. Red Devil's obligation under these warranties shall be limited to repairing or replacing, free of charge to the original purchaser, any part that, in Red Devil's judgment, shows evidence of such defect

## **Limitations to Warranty**

This warranty does not cover:

- 1) Warranty claims directly resulting from improper installation of the product.
- 2) Any product damaged by accident, abuse, misuse, or negligence after shipment from Red Devil.
- 3) Any unauthorized product alteration or modification.
- 4) Any unauthorized repairs made with parts other than genuine Red Devil parts.
- 5) Any repairs performed by anyone other than Red Devil or an authorized Red Devil dealer unless specifically authorized by Red Devil.
- 6) Snow Blower Fan Shafts.
- 7) Snow Blowers being used on a rental basis.

## **Warranty Procedure**

**Warranty registration form must be filled out and returned to Red Devil to validate all future warranty claims.**

- 1) Troubleshooting should be done between end user/dealer and Red Devil through our technical assistance @ 866-526-5682.
- 2) Labor reimbursement will occur only when pre-arranged through Red Devil's technical assistance. Lankota will reimburse labor based on it's current shop rate completed within a reasonable time using Red Devil's judgment.
- 3) There is no mileage reimbursement.
- 4) Diagnostic time will not be reimbursed except in pre-arranged circumstances.
- 5) Warranty claims should be on typical dealer service work order with a number and name to be attached for any future correspondence.
- 6) All warranty work must be performed and claims submitted within thirty (30) days of the occurrence of the claim and within the warranty period.
- 7) All parts removed during warranty repair should be held for a period of thirty (30) days after the warranty claim has been submitted to Red Devil.
- 8) Red Devil reserves the right to either inspect the product at the original retail purchaser's location or require it to be returned to Red Devil for inspection.

## **Limitation of Liability**

Red Devil makes no express warranties other than those, which are specifically described herein. Any description of the goods sold hereunder, including any reference to buyer's specifications and any descriptions in circulars and other written material published by Red Devil is for the sole purpose of identifying such goods and shall not create an express warranty that the goods shall conform to such description.

THIS WARRANTY IS EXPRESSLY IN LEU OF ALL OTHER WARRANTIES EXPRESSED OR IMPLIED. There are no warranties of merchantability or fitness of a particular purpose. This warranty states Red Devil's entire and exclusive liability and buyer's exclusive remedy or any claim for damages in connection with the sale of furnishing of Red Devil products, their design, suitability for use, installations or operation, or for any claimed defects herein. RED DEVIL WILL IN NO EVENT BE LIABLE FOR ANY INCIDENTAL OR CONSEQUENTIAL DAMAGES WHATSOEVER, NOT FOR ANY SUM IN EXCESS OF THE PRICE RECEIVED FOR THE GOODS FOR WHICH LIABILITY IS CLAIMED.

No representative of Red Devil nor any dealer associated with Red Devil has the authority to change the items of this warranty in any manner whatsoever, and no assistance to purchase by Red Devil in the repair or operation of any Red Devil product shall constitute a waiver of the conditions of this warranty, nor shall such assistance extend or revive it.

Lankota reserves the right to make improvements in design or changes in specifications at any time, without incurring any obligation to owners of units previously sold.

# Parts Book

ITEM NO.	PART NUMBER	DESCRIPTION	QTY.
1	RED8H	RED DEVIL 8' HOUSING ASSEMBLY	1
2	RED893P	RED DEVIL 8' & 9' 3-POINT ASSEMBLY	1
3	RED89-Powertrain	RED DEVIL 8' & 9' 540 POWERTRAIN	1
4	RED8AUG	RED DEVIL 8' AUGER	2
5	RED89SH	RED DEVIL 8' & 9' CHUTE ASSEMBLY	1

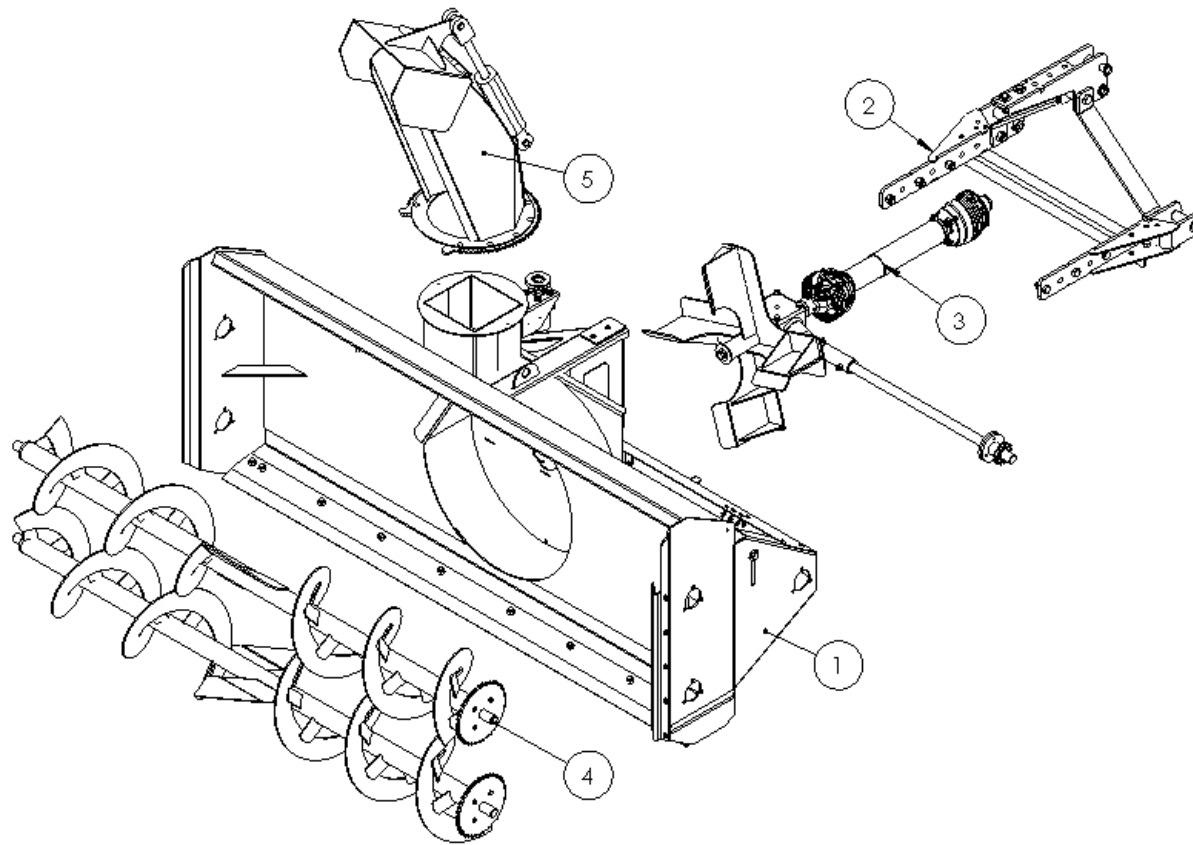

Refer to Figures 9a and 9b.

ITEM NO.	PART NUMBER	DESCRIPTION	QTY.
1	RED8H-0000	RED DEVIL 8' HOUSING	1
2	RED8H-0001D	RED DEVIL 8' BOLT ON CUTTING EDGE	1
3	RED-43844-89	RED DEVIL 8' & 9' SHEAR FLANGE SHIELD	1
4	RED89S-0010	RED DEVIL 8' & 9' CHAIN GUARD	1
5	RED-43699	RED DEVIL 8' & 9' PTO SHIELD	1
6	RED89H-SKIDS	RED DEVIL SKID SHOE WELDMENT	3
7	RED51039	RED DEVIL CHUTE ROTATION SPROCKET	1
8	RED10110	RED DEVIL CHUTE ROTATION MOTOR	1
9	RED01-315C	MANUAL HOLDER CANISTER	1
10	REDW742	SKID SHOE PIN	3
11	RED3234	ZERK FITTING 1/4"-28	2
12	REDKRJ8	5/16"-18 TOP LOCK NUT	7
13	LANF-CHS-0.313C-0.75	5/16"-18 x .75" CARRIAGE SCREW	3
14	REDB206	5/16-18 x 1.50" HEX HEAD CAP SCREW	4
15	LAN18000	3/8" FLAT WASHER	7
16	REDWL53	3/8" LOCK WASHER	28
17	REDNAF3	3/8" HEX NUT	24
18	LAN18A00	3/8"-16 x 1.00" HEX HEAD CAP SCREW	8
19	LAN26000	5/8" FLAT WASHER	14
20	REDKRJF	5/8"-11 TOP LOCK NUT	11
21	LAN18A	3/8"-16 X 1" CARRAIGE HEAD BOLT	20
22	RED706K	5/8"-11 x 1.50" CARRIAGE BOLT	10
23	LAN3726000	5/8"-11 x 4.00" HEX HEAD CAP SCREW	1
24	RED32710	1-3/8" BEARING ASSEMBLY	5
25	RED32711	BEARING HOLDER W/ ZERK 1-3/8" BEARING	5
26	RED32712	BEARING HOLDER 1-3/8" BEARING	5

Figure 9b.

Figure 9a.

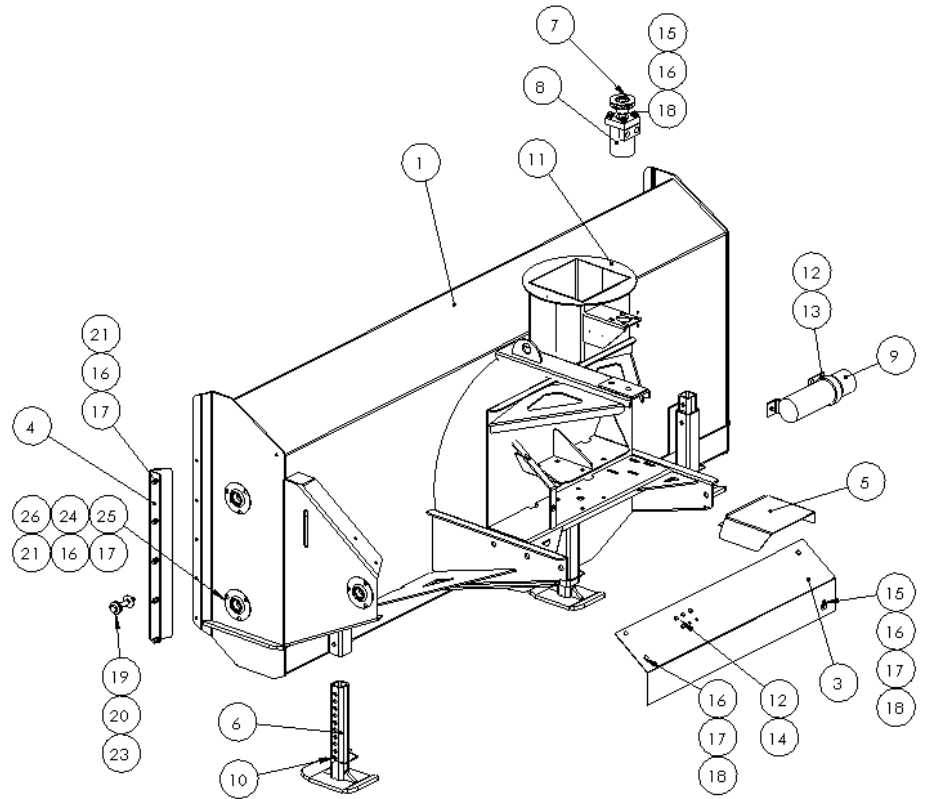
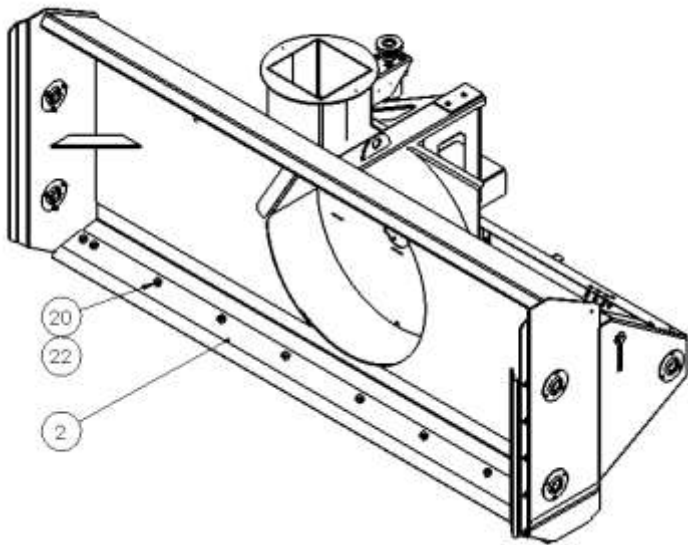

ITEM NO.	PART NUMBER	DESCRIPTION	QTY.
1	RED43797	RED DEVIL 8' & 9' 3-PT TOP MOUNT	1
2	RED43798	RED DEVIL 8' & 9' 3-PT LOWER MOUNT	2
3	RED893P-0002	RED DEVIL 8' & 9' 3-PT Z-BAR	2
4	RED893P-0003	RED DEVIL 8' & 9' 3-PT LOWER BRACE	1
5	RED21198	LIFT ARM BUSHING - CAT. 2 TO 3	2
6	RED21290	LIFT ARM PIN - CAT. 2	2
7	RED21192	TOP LINK BUSHING - CAT. 2 TO 3	1
8	RED21270	TOP LINK PIN - CAT. 3	1
9	RED21261	TOP LINK PIN - CAT. 2	1
10	RED21940	7/16" x 2" LINCH PIN	4
11	LAN26000	5/8" FLAT WASHER	2
12	REDKRJF	5/8"-11 TOP LOCK NUT	4
13	REDB706	5/8"-11 x 1.50" HEX HEAD CAP SCREW	2
14	REDB710	5/8"-11 X 2.50" HEX HEAD CAP SCREW	2
15	REDKRJG	3/4"-10 TOP LOCK NUT	6
16	REDB807	3/4"-10 x 1.75" HEX HEAD CAP SCREW	6
17	REDKRJ9	7/8" Top Lock Nut	3
18	REDB908	7/8"-9 x 2.0" HEX HEAD CAP SCREW	2
19	REDB922	7/8"-9 x 5.50" HEX HEAD CAP SCREW	1

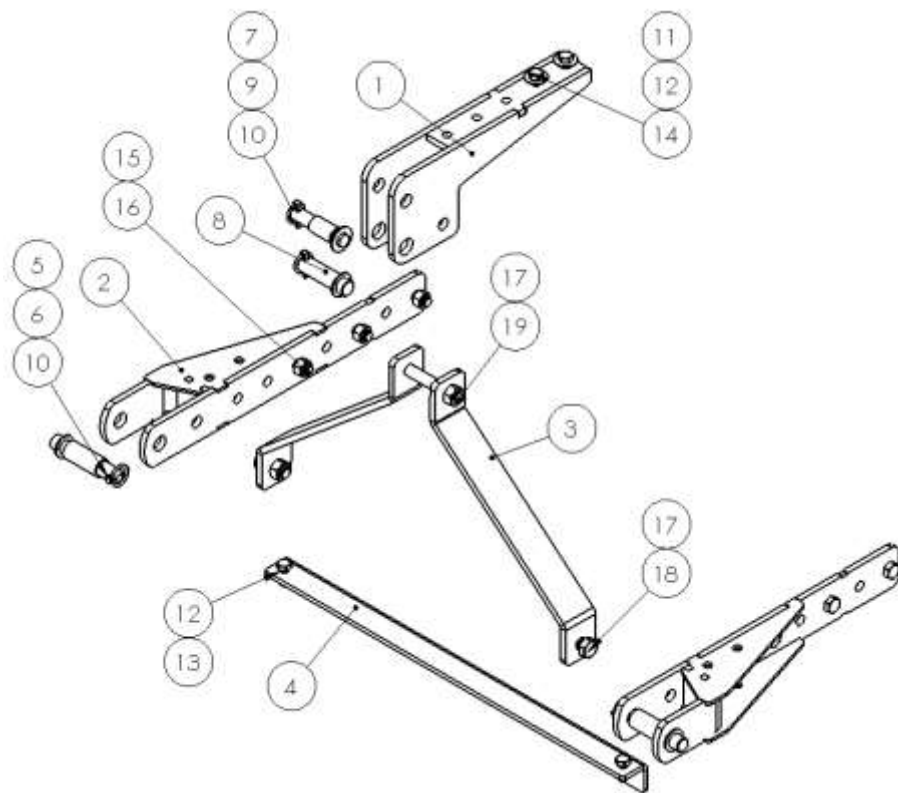

ITEM NO.	PART NUMBER	DESCRIPTION	QTY.
1	RED11082	RED DEVIL 8' & 9' GEAR BOX	1
2	RED89IMP	RED DEVIL 8' & 9' IMPELLER	1
3	RED252-23873	RED DEVIL DRIVELINE FOR 8' & 9' BLOWERS	1
4	RED32959	RED DEVIL 8' & 9' SHAFT COUPLER	1
5	RED02JK	MACHINE KEY 5/16" X 2.00"	4
6	REDKRJ8	5/16"-18 TOP LOCK NUT	1
7	REDB212	5/16"-18 x 3.00 HEX HEAD CAP SCREW	1
8	RED4GD0	7/16"-14 Top Lock Nut	2
9	REDB412	7/16" X 3.0" HEX HEAD CAP SCREW	2
10	REDWL55	1/2" LOCK WASHER	8
11	REDB504	1/2"-13 x 1.0" HEX HEAD CAP SCREW	8
12	LAN26000	5/8" FLAT WASHER	1
13	REDWL57	5/8" LOCK WASHER	1
14	REDB706	5/8"-11 x 1.50" HEX HEAD CAP SCREW	1
15	RED8SE	RED DEVIL 8' SHEAR FLANGE SHAFT	1
NA	RED034-6015	15 TOOTH IDLER PULLY FOR ANSI 60 CHAIN	1
NA	RED60RC	ANSI 60 CHAIN 113 LINK	1
NA	RED60CL	ANSI 60 CONNECTOR LINK	1

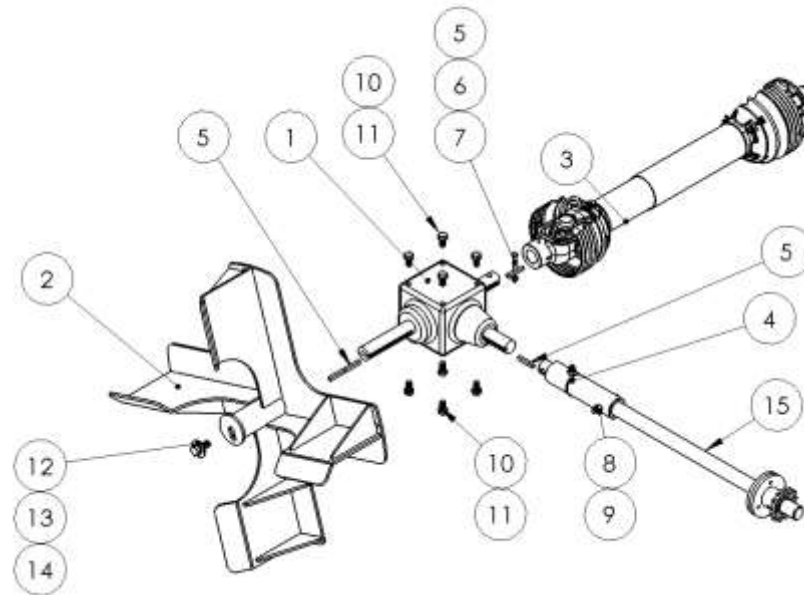

ITEM NO.	PART NUMBER	DESCRIPTION	QTY.
1	RED8AUGW	RED DEVIL 8' AUGER WELDMENT	1
2	RED32729	40T 60# CHAIN SPROCKET	1
3	RED0DTT	3/8"-16 TOP LOCK NUT	4
4	REDB306	3/8"-16 x 1.50" HEX HEAD CAP SCREW	4

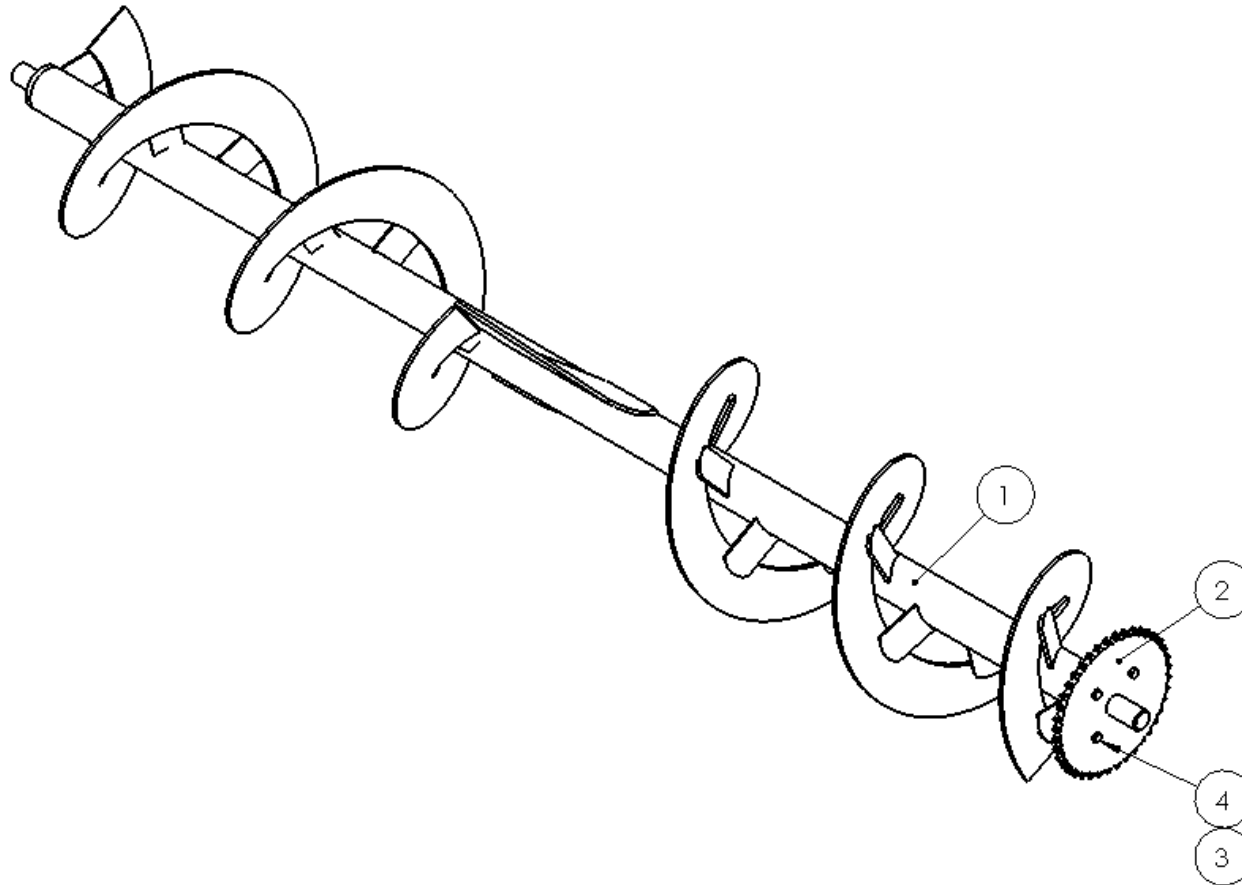



ITEM NO.	PART NUMBER	DESCRIPTION	QTY.
1	RED89SH-000C	RED DEVIL 8' & 9' CHUTE WELDMENT	1
2	RED89SH-000D	RED DEVIL 8' & 9' DEFLECTOR WELDMENT	1
3	RED-1000-CH-0116	RED DEVIL HINGE SHIELD	1
4	RED89SH-0005	RED DEVIL 8' & 9' CHUTE GEAR	2
5	RED89SH-0004	RED DEVIL 8' & 9' CHUTE GEAR CLAMP	2
6	RED2010111	2X8 DEFLECTOR CYLINDER	1
7	RED0DTT	3/8"-16 TOP LOCK NUT	14
8	LAN18A	3/8"-16 x 1.25" CARRIAGE SCREW	14
NA	RED-HH-70	70" HYDRAULIC HOSE	2
NA	RED-HH-90	90" HYDRAULIC HOSE	2
NA	LAN8010-4	1/2" NPT PIONEER HOSE END	4
NA	RED1404-8-8	1/2" NPT ORIFICE - 1/32"	1
NA	RED1501-6-8	3/8" MIP TO 1/2" FIP ELBOW	2

