

LANTC98022

Installation Instructions

Lankota Tow Cable Kit for:

All CIH® Magnum Rowtrac™ Tractors & Any 380 & Larger Magnum Tractors

LANKOTA®

**270 West Park Avenue
Huron, SD 57350
866-526-5682**

Numerical Parts List

Part Numbers	Description	Qty
LANTC980A	Tow Cable Bracket—CIH Magnum 380+	1
LANTC243	CIH Tow Cable Left Bracket	1
LANTC244	CIH Tow Cable Right Bracket	1
LANTC245	CIH Tow Cable Frame Hook	2
LANTC249	Cable Stow Arm, CIH Magnum	1
LANTC157	Tow Cable—1.25" x 16ft	1
LANTC209	1-3/8" Cable Shackle	1
LAN8RTC005BLK	Tow Cable Slack Bracket	1
LAN8RTC006BLK	Cable Clamp	2
LAN8RTC016BLK	Mid Cable Support	1
LANTCR320856	Tow Cable Storage Pin	1
LANTCT160263	Oversize Washer for Tow Cable	1
LANFHT1XC	Hex Head Cap Screw—1-1/2"-6 x 10", Grade 8	1
LANFHN79	Hex Nut—1-1/2"-6, Grade 8	1
LANFR8V9	Hex Head Cap Screw—M12-1.75 x 50mm, Grade 10.9	4
LAN18A	Carriage Bolt—3/8"-16 x 1	4
LAN3718	Serrated Flange Nut—3/8"-16, Grade 5	4
LANFB305	Hex Head Cap Screw—3/8"-16 x 1-1/4", Grade 5	2
LANFWS53	SAE Flat Washer—3/8"	2
LANFNW7G	Flanged Nylon Lock Nut—3/8"-16, Grade 5	2
LANF1ERQ	Carriage Bolt—1/2"-13 x 2"	4
LAN3722	Serrated Flange Nut—1/2"-13, Grade 5	4
LANF1T2M	Hex Head Cap Screw—M20-2.5 x 60mm, Grade 10.9	2
REDWU58	Flat Washer—3/4"	2
LANFNAS7	Serrated Flange Nut—3/4"-10, Grade 5	1
RED21940	Linch pin—7/16" x 1-1/2"	1

Pictorial Parts List - Common Parts

Installation

Refer to Figure 1 & 2

1. Remove the factory draw bar mount and set aside, retaining the hardware. Slide the factory draw bar back out of the way.
2. Bolt the Tow Bracket (LANTC980A) to the frame with the factory hardware. Tighten the hardware.

Figure 1



Figure 2

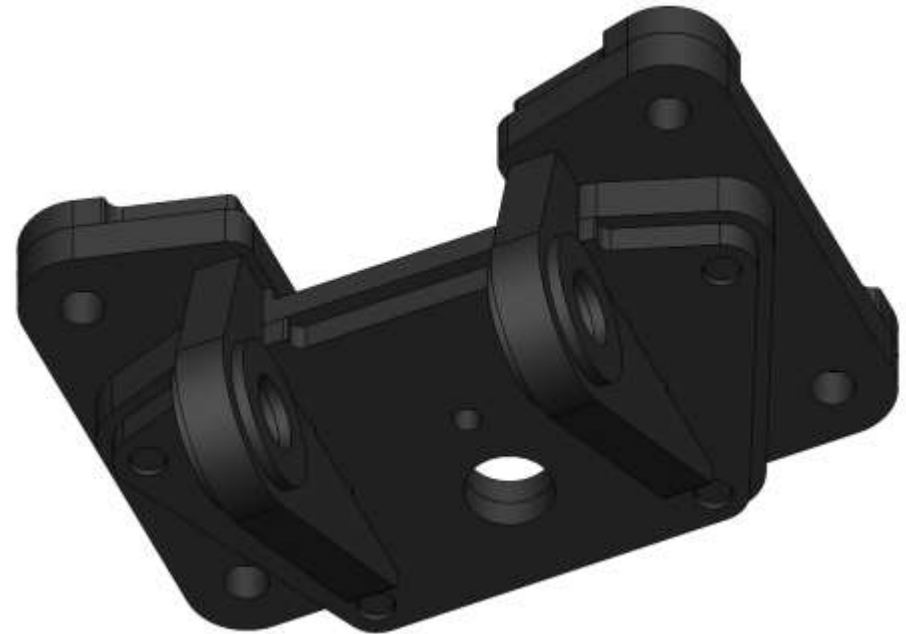

Installation

Refer to Figure 3 & 4

3. Re-install the drawbar into the new Tow Bracket (LANTC980A) using factory hardware. Tighten the hardware.
4. Slide the 1-3/8" Cable Shackle (LANTC209) through one end of the Tow Cable (LANTC157) and attach it to the Tow Bracket using the 1-1/2"-6 x 10" Grade 8 Hex Head Cap Screw (LANFHT1XC) and the 1-1/2"-6 Grade 8 Hex Nut (LANFHN79). Tighten this hardware.

Figure 3



Figure 4



Installation

Refer to Figure 5 & 6

5. Remove the two outside bolts on the bottom/back side of the front axle differential and install the CIH Tow Cable Left/Right Brackets (LANTC243 & LANTC244) on their respective sides. You will use the provided M12-1.75 x 50mm, Grade 10.9 Hex Head Cap Screws (LANFR8V9) in place of the factory hardware.
6. Install the Frame Hooks (LANTC245) on the outside of the Left/Right brackets using the provided 3/8"-16 x 1" Carriage Bolts (LAN18A) and 3/8"-16 Serrated Flange Nuts (LAN3718).

Figure 5



Figure 6



Installation

Refer to Figure 7

7. Install the Tow Cable Slack Bracket (LAN8RTC005BLK) and Mid Cable Support (LAN8RTC016BLK) around the cable and attach to the front side of the Left/Right Brackets (LANTC243 & LANTC244). Use the provided 1/2"-13 X 2" Carriage Bolts (LANF1ERQ) and 1/2"-13 Serrated Flange Nuts (LAN3722) to fasten. Tighten all hardware at this time.

Figure 7



Installation

Refer to Figure 8

8. Place both Cable Clamps (LAN8RTC006BLK) around the cable on the FRONT side of the Mid Cable Support and loosely install the provided 3/8"-16 x 1-1/4" Hex Head Cap Screws (LANFB305), the 3/8" Flat Washers (LANFWS53), and the 3/8"-16 Flanged Nylon Lock Nuts (LANFNW7G).
9. Pull the cable tight to remove any slack, while another person slides the Cable Clamps up tight to the Mid Cable Support and tightens the hardware. This will remove any slack in the cable in the middle of the tractor.

Figure 8



Installation

Refer to Figure 9 & 10

10. Remove the toolbox bracket on the left side of the tractor and place the Cable Stow Arm (LANTC249) behind it. Fasten with the provided M20 -2.5x 60mm Hex Head Cap Screws (LANF1T2M) and 3/4" Flat Washers (REDWU58).

Figure 9



Figure 10



Installation

Refer to Figure 11 & 12

11. Hold the end of the cable up to the stow bracket to determine which hole needs to be used in the Stow Arm to keep it up off the ground. Tighten the Tow Cable Storage Pin (LANTCR320856) in the appropriate location using the 3/4"-10 Serrated Flange Nut (LANFNAS7).
12. Slip the cable end of the storage pin and retain with the Oversized Washer (LANTCT160263) and 7/16" x 1-1/2" Linch Pin (RED21940).

Figure 11



Figure 12

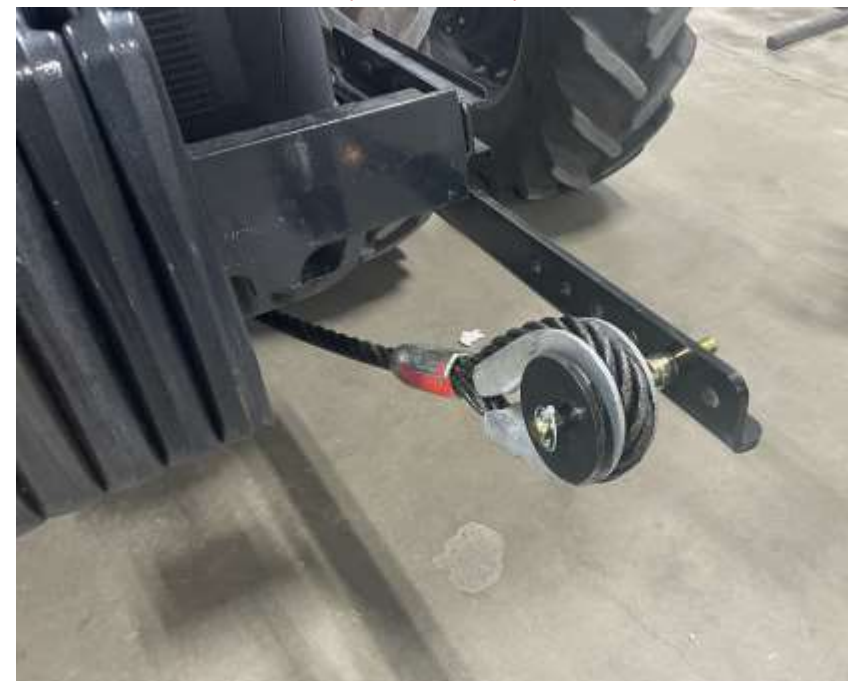

For further technical assistance,
Call Lankota Inc. at:
1-866-526-5682