

# **LANSSDR630R4GT**

## **Installation Instructions**

**Lankota GENERATION II Stalk Stomper® Kit for Drago® 630 GT Series Corn Head - 4 Row Coverage**

# **LANKOTA®**

**270 West Park Avenue  
Huron, SD 57350  
866-526-5682**

# Numerical Parts List

<b>Part Numbers</b>	<b>Description</b>	<b>Quantity</b>
LANSSDRGT201	Drago GT Stalk Stomper Mount	1
LANSSDRGT202	Drago GT Stalk Stomper Mount	1
LANSSDRGT103	Drago GT Stalk Stomper Mount	1
LANSSDRGT104	Drago GT Stalk Stomper Mount	1
LANSSDRGT106	PTO Holder	2
LANSS659	Straight Flip Up Mount	4
LANSSB42BLK	42" Stomper Bar, Black	2
<b>LANSSDR630R4GTBH</b>	<b>Box of Hardware</b>	<b>1</b>
LAN600UBOLT	U-bolt 5/8" x 2.265" ID x 3.75" Length	8
LAN690830	5/8"-11 Serrated Flange Nut	16
LANFG36R	M12 x 30 CLS8.8 Hex Flange Bolt	22
<b>LANSS668BH</b>	<b>Bag of Hardware for SS668</b>	<b>4</b>
LAN600UBOLT	U-bolt 5/8" x 2.265" ID x 3.75" Length	2
LAN690830	5/8"-11 Serrated Flange Nut	4
LANFNXC1	1/2"-13 Flanged Nyloc Nut	1
LANFNHVK	1/2"-13 x 2.5" Flanged Cap Screw	1

# Pictorial Parts List

			
LANSSDRGT201 (1)	LANSSDRGT202 (1)	LANSSDRGT103 (1)	LANSSDRGT104 (1)
			
LANSSDRGT106 (2)	LANSS659 (4)	LANSSB42BLK (2)	LANFG36R (22)
			
LAN600UBOLT (16)	LAN690830 (32)	LANFNHVK (4)	LANFNXC1 (4)

# Preparation

1. Attach desired header to the combine. Lock the head to the combine.
2. Raise the head off the ground and lower the safety stop on the feeder house cylinder.
3. Set the parking brake on the combine.
4. Turn off the combine engine and remove the key.

## 1. Install Brackets & Bars

Refer to Figures 1.1, 1.2 & 1.3

- 1.1 Remove the PTO Holder from both sides of the head.
- 1.2 Remove the three bolts on each end of the head that are shown.
- 1.3 Turn PTO shield so it is taller than wide as shown.



Figure 1.1



Figure 1.2



Figure 1.3

# 1. Install Brackets & Bars

## Refer to Figure 1.4

**1.4** Install mount LANSSDRGT201 on the right side of the head and LANSSDRGT202 on the left side using three M12 flange bolts (LANFG36R) each. Use the holes exposed in the earlier step. Tighten.

**\*Note the order that the pieces go together in (see Figure).**

## Refer to Figure 1.5

**1.5** Install mount LANSSDRGT103 on the right side of the feederhouse and LANSSDRGT104 on the left side using six M12 x 30mm flange bolts (LANFG36R) each. Tighten.

**Note:** There are two sets of holes to choose from. As a guideline, the top holes should be used when the head will be running at the steepest angle and/or be carried away from the ground more than 6 inches.



Figure 1.34

Figure 1.5

# 1. Install Brackets & Bars

## Refer to Figure 1.5

**1.5** Install the PTO Hooks (LANSSDRGT106) on both sides of the feederhouse in the outer set of holes as shown with two M12 flange bolts. Tighten and set the PTO shafts into the hooks.

## Refer to Figure 1.6 & 1.7

**1.6** Install a 42" toolbar on each side of the head using two U-bolts and four 5/8" serrated flange nuts at each bracket as shown.

**1.7** Slide the bar inwards until the outside end is almost flush with the outer bracket and tighten. The bar will jut in towards the feederhouse.



Figure 1.6

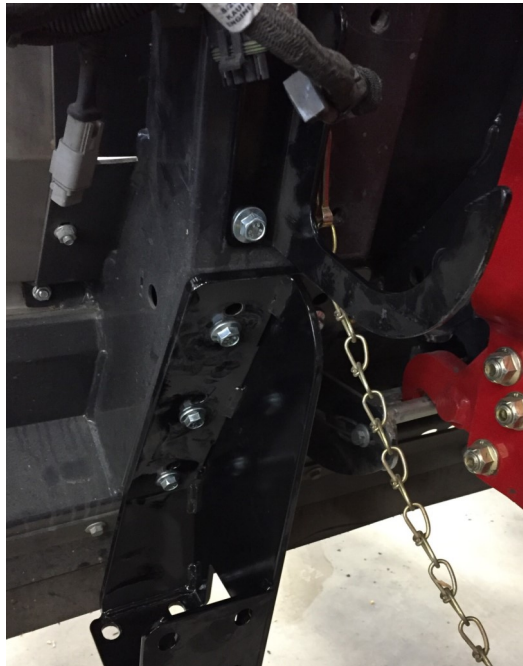

Figure 1.5

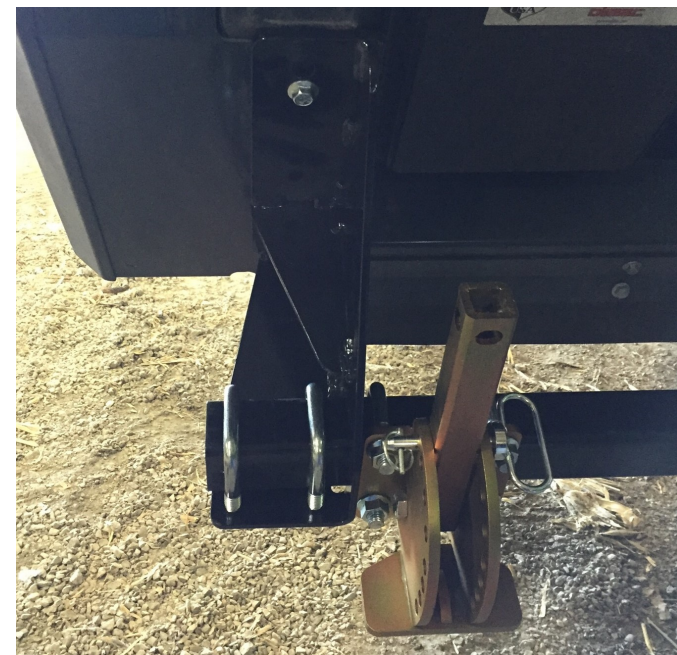

Figure 1.7

## 2. Install Shoes & Mounts

Refer to Figure 2.1 & 2.2

2.1 Install the LANSS659 flip-up mounts on the outside rows. Each mount sits directly behind a row and mounts on the backside of the bar with two U-bolts and four nuts.



Figure 2.1



Figure 2.2

## 2. Install Shoes & Mounts

Refer to Figure 2.3

2.2 Attach the outer four shoes to the flip-up mounts using the 1/2" Flanged bolts and nuts.

Figure 2.3

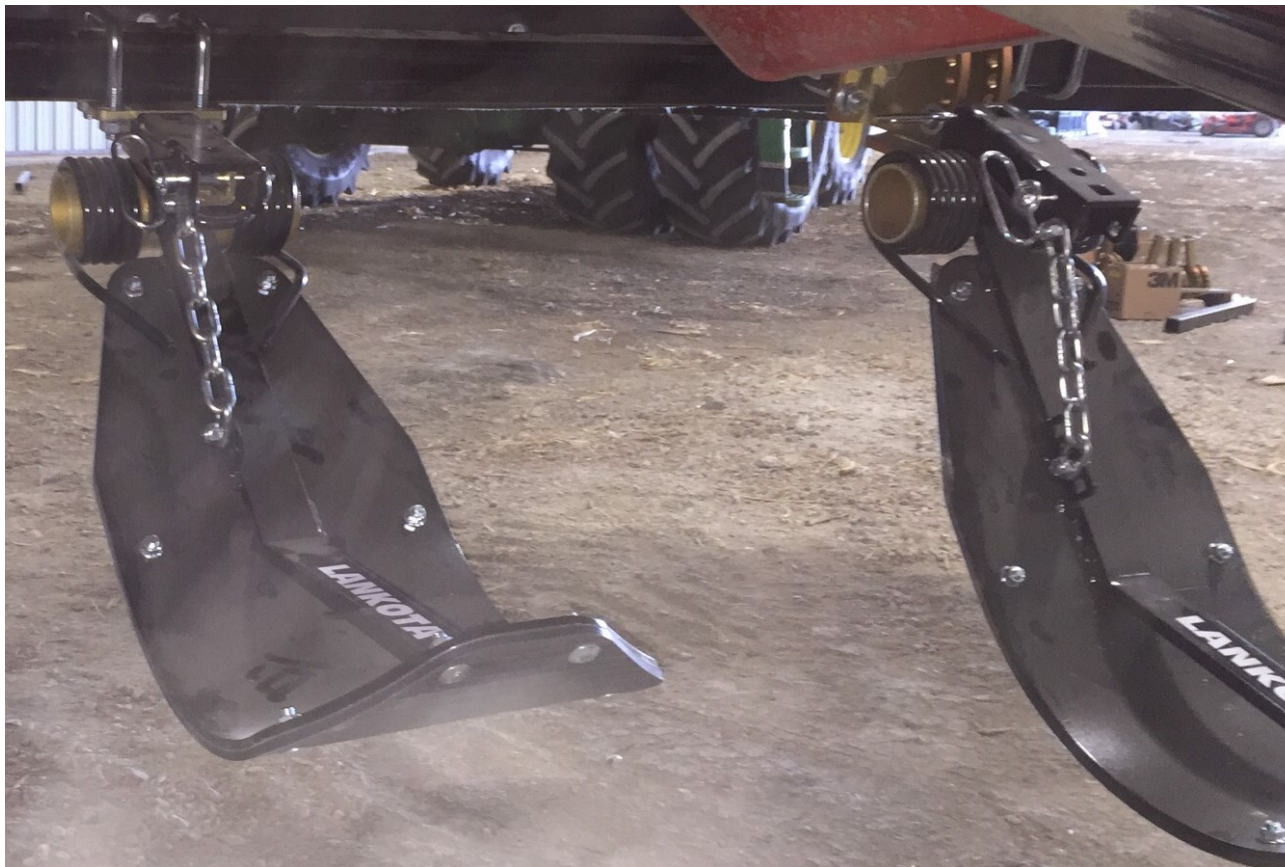



# Stalk Stomper Disclaimer

## *Stalk Stomper Disclaimer*

The most effective use of the Lankota Stalk Stomper® is achieved by adjusting the stomper pad so that when the corn head is at its normal cutting height, the pad of the shoe is 1" above the ground. Over compression of the spring can shorten the life of the stomper spring, increase wear on the poly liner, and may result in undue damage NOT covered by Lankota's Limited Warranty.

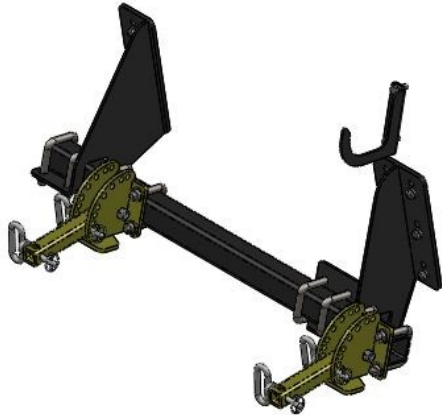

For further technical assistance,

call Lankota Inc. at:

1-866-526-5682

