

LANSRCIHM3

Installation Instructions

Lankota Stalk Roller Kit for Case IH® Magnum Series Tractors

This kit DOES NOT work on tractors equipped with the LARGE weight bracket (CIH Part # 48152101)

LANKOTA®

270 West Park Avenue
Huron, SD 57350
866-526-5682

Numerical Parts List

Part Numbers	Description	Qty
LANSRCIH301	CIH Stalk Roller Tier 4 Mount	1
LANSRCIH002	CIH Stalk Roller Weights Bolt	1
LANSR003BLK	FWA Stalk Roller Assembly	2
LANSR005BLK	FWA Stalk Roller Mount Frame	1
LANSR006BLK	FWA Stalk Roller Wing Frame	1
LANSR007BLK	FWA Stalk Roller Wing Frame	1
LANSR008	FWA Stalk Roller Wing Pin	2
LANSR009	FWA Stalk Roller Plastic Washer	4
LANW250100-S	Hydraulic Cylinder for Stalk Rollers	2
LANSS704	Stalk Stomper Pin Assembly - Bent Pin	2
LANSKA-1	1" Cylinder Stroke Control	4
LANSRCIH003	Accumulator Mount	1
LANSRJD8RHK	FWA CIH Stalk Roller Hose Kit	1
-----	28" Hydraulic Hose - 3/8"	2
-----	40" Hydraulic Hose - 3/8"	2
-----	26' (312") Hydraulic Hose - 3/8"	2
-----	9/16" Male JIC to 9/16" Male ORB	2
-----	9/16" Male JIC Tee	2
-----	1/2" Female NPT Quick Coupler	2
-----	1/2" Female NPT to 1/2" Male NPT Tee	2
-----	1/2" NPT Male Coupling	2
-----	9/16" Male JIC to 1/2" Male NPT	2
-----	9/16" Male JIC to 9/16" Male ORB 90 Deg.	4

Numerical Parts List (Continued)

Part Numbers	Description	Qty
LANSRCIHM3BH	Box of Hardware Includes:	1
LANF3231	Grease Zerk - 1/4"-28	4
LANF-HHCS-M24-80	M24 x 80 Gr 10.9 Hex Bolt	6
LANF0FC4	M24 Lock Washer	6
LANF-FW-M24	M24 Flat Washer	14
LANFC507	1/2-13 x 1.75" Gr 8 Hex Bolt	2
RED1F30	1/2" Top Lock Nut	2
REDB710	5/8-11 x 2.5" Gr 5 Hex Bolt	8
LANFWS57	5/8" SAE Flat Washer	8
LAN690830	5/8" Serrated Flange Nut	24
LAN26000	5/8" Flat Washer	1
LAN1626000	5/8" Nyloc Nut	1
LAN079UBOLT	U-Bolt - 5/8"-11 x 6.5"	8
LAN25162	Hose Clamp	2
LAN18A00	3/8" x 1.0" Gr 5 Hex Bolt	2
LANFWS53	3/8" SAE Flat Washer	2
RED0DTT	3/8" Top Lock Nut	2
LAN44302	Zip Tie, 11"	10

Pictorial Parts List

					
LANSRCIH301 (1)	LANSRCIH002 (1)	LANSR003BLK (2)	LANSR005BLK (1)	LANSR006BLK (1)	LANSR007BLK (1)
					
LANSR008 (2)	LANSR009 (4)	LANSRCIH003 (1)	LANW250100-S (2)	LANSS704 (2)	LANSCA-1 (4)
					
LANFC507(2)	RED1F30 (2)	LANF-HHCS-M24-80 (6)	LANF0FC4 (6)	LANF-FW-M24 (6)	REDB710 (8)
					
LANFWS57 (8)	LAN690830 (24)	LAN26000 (1)	LAN1626000 (1)		LAN079UBOLT (8)

Pictorial Parts List (Continued)

				
LAN25162 (2)	LAN18A00 (2)	LANFWS53 (2)	RED0DTT (2)	LAN44302 (10)

Disclaimer

This kit from LANKOTA adds 1300 lbs. to the front of a tractor. Never exceed manufacturer's specified load limit on the front of a tractor! This may mean that weights may need to be removed from the tractor to install this kit.

WARNING: After completing installation, be careful around the wings the first dozen or so times they are folded/unfolded. The process of purging the air from the hoses can cause the wings to jerk up and down dangerously and unexpectedly.

1. Installation

NOTE: If your tractor has hydraulic front suspension, you may need to re-locate the accumulator to properly attach the LANSRCH301.

- Start by removing the accumulator shield and removing the accumulator from the shield.
- Move the accumulator back out of the way
- Install the Stalk Roller Mount (LANSRCH301) via the instructions on the next page.



1. Installation

1. Remove any weights necessary. (See the previous disclaimer)

Refer to Figures 1 & 2

2. Clean out the threaded holes on the bottom of the frame behind the weights and in front of the front axle.
3. Lift the mount LANSRCH301 into place and attach it with the M24 bolts and lock washers. Use a small amount of RED thread locker on the bolts. Tighten well.

Figure 1



Figure 2

1. Installation

NOTE: If your tractor has hydraulic front suspension, you may need to re-locate the accumulator to properly attach the LANSRCH301.

- Attach the accumulator to the Lankota Accumulator Mount (LANSRCH003) using factory hardware.
- Remove the middle set of bolts in the stalk roller mount and re-install them with the Accumulator Mount (LANSRCH003).



1. Installation

Refer to Figure 3

4. There are two sets of holes in the mount. Ideally, the top pair of bolts will be 27" to 30" off the ground when the mount frame (LANSR005) is bolted to the mount.
5. Lift the mount frame into place and secure it with the 5/8" bolts (REDB710), washers (LANFWS57) and serrated lock nuts (LAN690830). Tighten all hardware. **Make sure the washers are on the bolt head side of the plate!**

Figure 3



1. Installation

Refer to Figures 4 & 5

6. Plastic washers (LANSR009) are provided to eliminate metal to metal contact between the wing frames (LANSR006 & LANSR007) and the mount frame (LANSR005). Make sure these are in place in the following step.
7. Using the pivot pins (LANSR008), attach the wing frames to the mount frame. Retain the pivot pin with the provided 1/2" bolt (LANFC507) and lock nut (RED1F30). When in the driver's seat, LANSR006 will be on your left, and LANSR007 will be on your right.
8. Install grease zerks and grease pins.

Figure 4

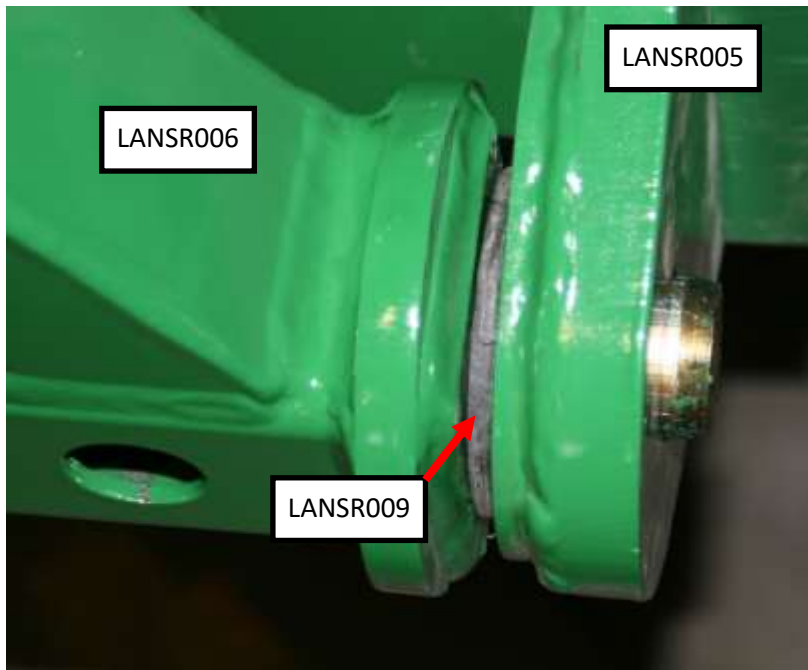

Figure 5



1. Installation

Refer to Figures 6 & 7

9. Using the provided 5/8" U-bolts (LAN079UBOLT) and serrated flange nuts (LAN690830), attach the row mounts to the stalk roller wing frames (LANSR006 & LANSR007). Make sure to position the drums so they are centered over the duals.

NOTE: The roller drum will be angled toward the back of the tractor.

10. Install the hydraulic cylinders (LANW250100-S) with included pins. Make sure the ports are facing toward the tractor and that the rod end is connected to the wing frames (LANSR006 & LANSR007).

11. When the cylinder is completely extended, the wing frame should be parallel to the ground. There is room for some adjustment by screwing the clevis in/out of the rod.



Figure 6

Figure 7



2. Hydraulic Installation

ITEM NO.	DESCRIPTION	QTY.
1	9/16" MALE JIC TEE	2
2	1/2" FEMALE NPT QUICK COUPLER	2
3	1/2" FEMALE NPT TO 1/2" MALE NPT TEE	2
4	1/2" NPT MALE NIPPLE COUPLING	2
5	9/16" MALE JIC TO 9/16" MALE ORB	2
6	9/16" MALE JIC TO 1/2" MALE NPT	2
7	9/16" MALE JIC TO 9/16" MALE ORB 90 DEG	2
8	9/16" JIC MALE TO FEMALE - 1/32" ORIFICE	2

* 3/8" Diameter Hoses



Every hose end is crimped with a straight swivel flange fitting.

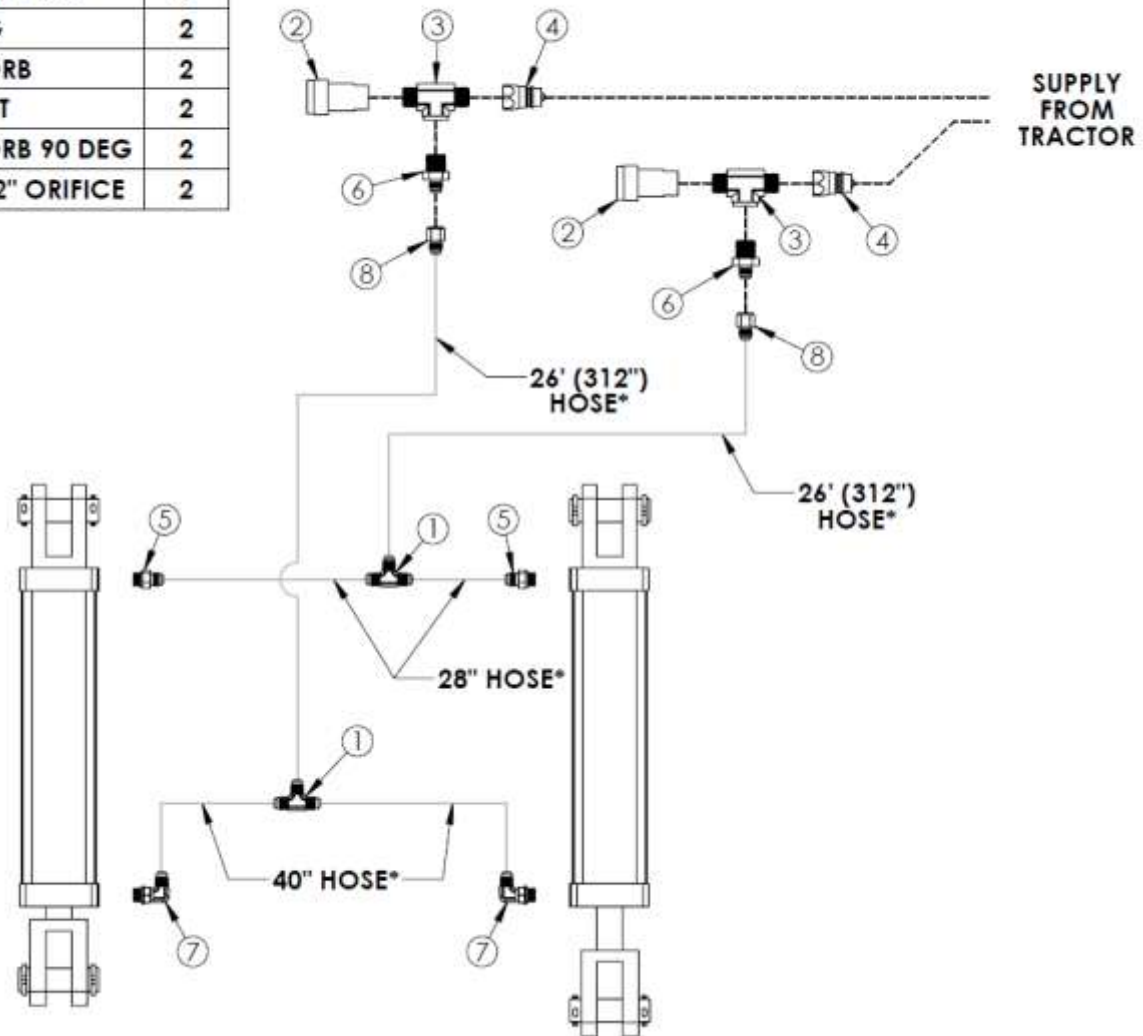

2. Hydraulic Installation

Refer to Figures 8 & 9

12. Attach a straight fitting on the base end of the cylinder and a 90 degree fitting on the rod end of the cylinder. A 28" hose will be attached to the straight fitting. A 40" hose will be attached to the 90 degree fitting. Do this on each cylinder.
13. Both sets of hoses will meet up and attach to the tee fittings in the middle. Make sure cylinder base hoses are together and rod end hoses are together. Also make sure that the hoses have enough freedom to move as the wing frames rotate up 90 degrees. Attach the two 312" hoses to the tee fittings and route them through the tube in LANSRCIH301, up through the cast frame and along the plastic side panel/wheel well of the tractor.



Figure 8

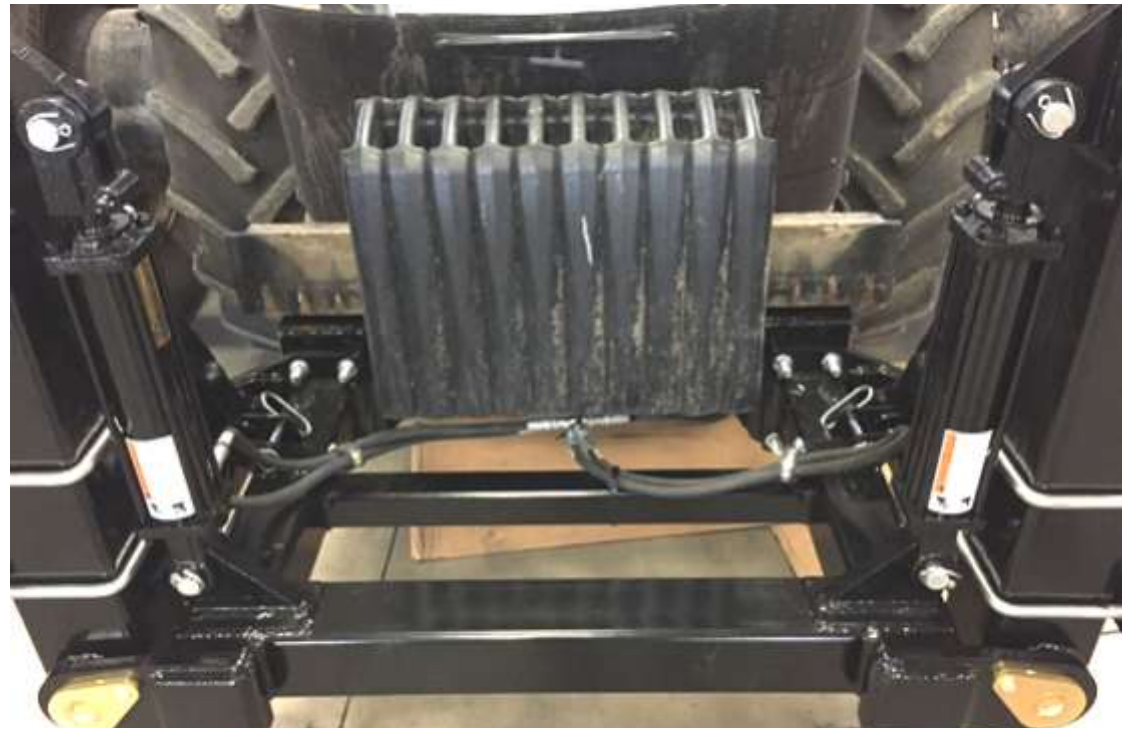

Figure 9

2. Hydraulic Installation

Refer to Figures 10 & 11

14. Use zip ties to retain the hoses as needed.

Note: Use the plugs from the cylinders to cap the hoses to keep them clean.



Figure 10

Figure 11



2. Hydraulic Installation

Refer to Figures 12 & 13

15. Route the hoses along the side of the tractor and then under the cab to the back.

Figure 12



Figure 13

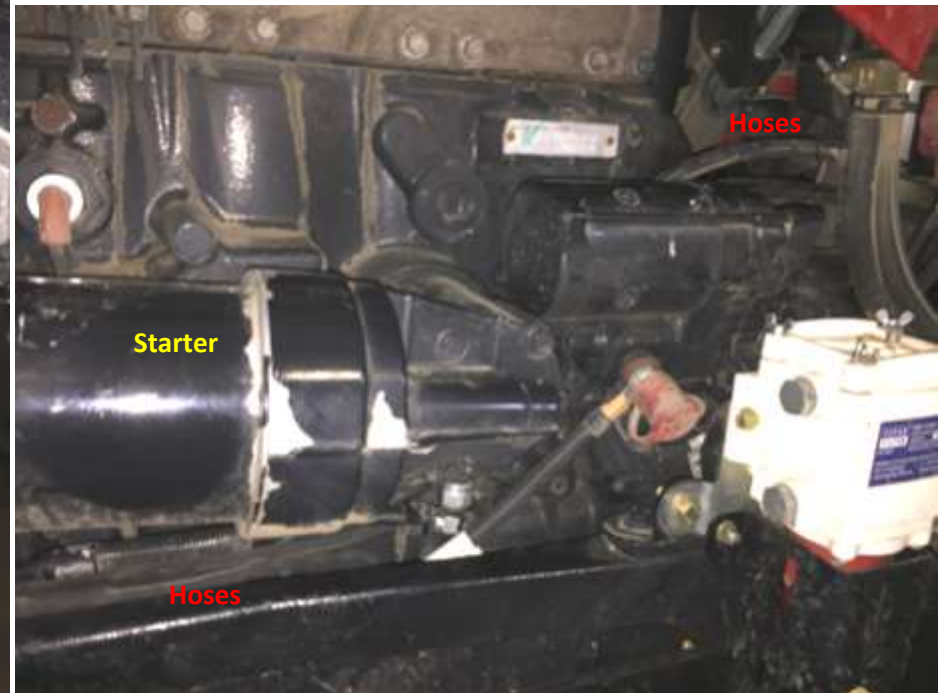

2. Hydraulic Installation

Refer to Figures 14

16. Route the hoses out the back of the tractor. Attach the hose to the NPT tee fitting and quick couplers as shown in the schematic. They can now be plugged into one of the auxiliary ports at the back of the tractor.
17. Keep the hoses in front of the weight bracket contained using the hose clamps (LAN25162) and 3/8" bolts, washers and lock nuts (LAN18A00, LANFWS53 and RED0DTT).

Figure 14



Figure 15



Figure 16



2. Hydraulic Installation

Refer to Figures 17 & 18

18. Two pins (LANSS704) are included to hold the wing frames UP during long term storage. Their purpose is to keep the wing assemblies from settling during long-term storage. An extra hole is provided for storage of the pin while the rollers are in use.

Storage Position



Figure 17

Operating Position



Figure 18

Headlight Clearance Consideration

Refer to Figures A, B & C

If additional light clearance is required, install cylinder stops (LANSCA-1) as necessary (one or two) on each cylinder to hold the roller arms away from the lights.

Note: The cylinder stops will need to be removed in order to utilize the storage pin position (See Figure C).



Figure A

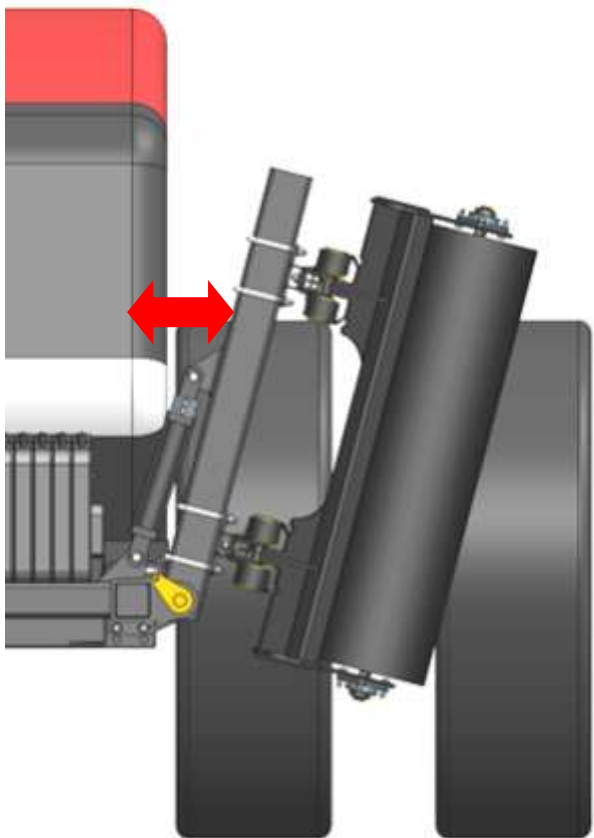

Figure B

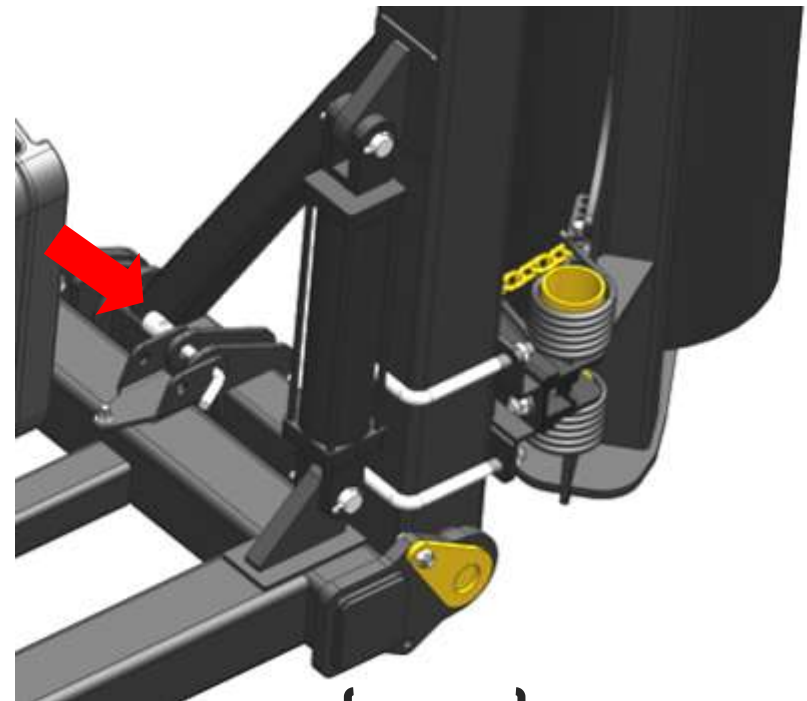

Figure C

Stalk Roller Disclaimer

The most effective use of the Lankota Stalk Roller is achieved by adjusting the chain on the roller so that when they are unfolded, the roller drum is just touching the ground and the spring is not compressed. Over compression of the spring can shorten the life of the roller spring and may result in undue damage NOT covered by Lankota's Limited Warranty.

For further technical assistance,

Call Lankota Inc. at:

1-866-526-5682

