

LANSR8568474

Installation Instructions

Lankota Stalk Roller Kit for Fendt 900 series and Caterpillar MT700 Series Track Tractors

LANKOTA[®]

**270 West Park Avenue
Huron, SD 57350
866-526-5682**

Numerical Parts List

Part Numbers	Description	Qty
LANSR150	MT738 Stalk Roller Mount LH	1
LANSR150M	MT738 Stalk Roller Mount RH	1
LANSR151	MT738 Center Support Bracket	2
LANSR152	MT738 Center Bracket	2
LANSR035BLK	Stalk Roller Assembly-74"	2
LANSR038BLK	Stalk Roller Wing Frame	1
LANSR039BLK	Stalk Roller Wing Frame	1
LANSR008	Stalk Roller Wing Pin	2
LANS600JBLK	Joint Plate for 2.5" Square Tube	1
LANSCA-1	1" Cylinder Stroke Control	4
LANW250100-S	Hydraulic Cylinder for Stalk Roller	2
LAN079UBOLT	UBOLT—5/8" x 5.125" ID x 6.5" Long	4
LAN690830	Serrated Flange Nut 5/8" - 11, Gr.5	8
LANSR856BH	Box of Hardware	1
LANSR009	Stalk Roller Plastic Washer	4
LAN079UBOLT	UBOLT—5/8" x 5.125" ID x 6.5" Long	8
LAN600UBOLT	UBOLT—5/8" x 2.625" ID x 3.75"	8
LAN690830	Serrated Flange Nut 5/8" - 11, Gr.5	32
LANB718	HHCS—5/8" - 11 x 4.5", Gr.5	6
LANF1T2M	HHCS—M20—2.5 x 60, Gr. 10.9	8
LANFC507	HHCS—1/2" - 13 x 1.75, Gr.8	2
LANFM8N7	HHCS—M20—2.5 x 140, Gr.10.9	4
LANFMLW0	Lock Washer—M20	12
LANFWS55	SAE Flat Washer—1/2"	2
LANFWS57	SAE Flat Washer—5/8"	12
LANS704	Twist Lock Pin—Bent	2
RED1F30	Top Lock Nut—1/2" - 13, Gr.5	2
REDKRJF	Top Lock Nut—5/8" - 11, Gr.5	6
LAN44302	Zip Tie, 11"	12









Numerical Parts List (Continued)

Part Numbers	Description	Qty
LANSRJD8RHK	Stalk Roller Hose Kit	1
-----	26' (312") x 3/8" Hydraulic Hose, JIC 6F	2
-----	28" x 3/8" Hydraulic Hose, JIC 6F	2
-----	40" x 3/8" Hydraulic Hose, JIC 6F	2
-----	52" x 3/8" Hydraulic Hose, JIC 6F	2
-----	64" x 3/8" Hydraulic Hose, JIC 6F	2
-----	1/32" Orifice Male to Female Adapter	2
6400-06-06	9/16" Male JIC to 9/16" Male ORB	2
2603-06-06-06	9/16" Male JIC Tee	2
DINB12-F-08N	1/2" Female NPT Quick Coupler	2
5601-08-08-08	1/2" Female NPT to 1/2" Male NPT Tee	2
DINB12-MS-08N	1/2" NPT Male Coupling	2
2404-06-08	9/16" Male JIC to 1/2" Male NPT	2
6801-06-06	9/16" Male JIC to 9/16" Male ORB 90 Deg	4
LANSRHRTBH	Bag of Hardware Includes:	1
LAN25162	Double 1" Hose Clamp with Cushion	2
REDB204	Hex Head Cap Screw—5/16"-18 x 1.00", gr. 5	2
LANFWS52	5/16" SAE Flat Washer	2
LAN1616	Nyloc Nut - 5/16"-18, gr. 5	2
LAN44302	11" Zip Tie	12

Pictorial Parts List

LANSR150 (1)		LANSR150M (1)		LANSR151 (2)	
LANSR152 (2)	LANSR035BLK (2)	LANSR038BLK (1)	LANSR039BLK (1)	LANSR008 (2)	LANSR009 (4)
LANSS600JBLK (1)	LANSCA-1 (4)	LANW250100-S (2)	LAN079UBOLT (12)	LAN600UBOLT (8)	LAN690830 (40)
LANB718 (6)	LANF1T2M (8)	LANFC507 (2)	LANFM8N7 (4)	LANFMLW0 (12)	LANFWS55 (2)

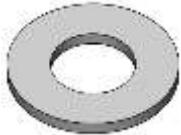
Pictorial Parts List (Continued)

				
LANFWS57 (12)	LANSS704 (2)	RED1F30 (2)	REDKRJF (6)	LAN25162 (2)
				
REDB204 (2)	LANFWS52 (2)	LAN1616 (2)	LAN44302 (12)	

Disclaimer

This kit from LANKOTA adds 1300 lbs. to the front of a tractor. Never exceed manufacturer's specified load limit on the front of a tractor! This may mean that weights may need to be removed from the tractor to install this kit.

WARNING: After completing installation, be careful around the wings the first dozen or so times they are folded/unfolded. The process of purging the air from the hoses can cause the wings to jerk up and down dangerously and unexpectedly.

Kit Installation

Refer to Figures 1 & 2

1. Attach the Stalk Roller Mounts (LANSR150 & LANSR150M) to both sides of the tractor. Use M20 x 60, Gr.10.9 hex bolts (LANF1T2M) & M20 lock washers (LANFMLW0) on both sides.
2. Loosely install hardware, do not tighten mounts at this time.
3. Remove bottom weight bolts indicated with arrow. Install Center Brackets (LANSR152) using M20 x 140, Gr. 10.9 bolts (LANFM8N7) & M20 lock washers (LANFMLW0). Tighten hardware.

Figure 1



Figure 2



Kit Installation

Refer to Figure 3—5

4. Install Center Support Brackets (LANSR151) to Stalk Roller Mounts (LANSR150 & LANSR150M) using 5/8" x 4 1/2" bolts (LANB718) with flat washers (LANFWS57) on both sides & 5/8" top lock nuts (REDKRJF). Keep hardware snug, don't tighten at this time.
5. Loosely install U-bolts (LAN600UBOLT) using 5/8" serrated flange nuts (LAN690830) connecting center support bracket (LANSR151) to center bracket (LANSR152) bolted to front weight.
6. After U-bolts are installed, set a level on a flat surface on Stalk Roller Mounts. Once level tighten hardware to secure mounts to side of tractor frame.

Figure 4



Figure 3



Figure 5



Kit Installation

Refer to Figures 6—8

7. After Stalk Roller Mounts are tightened, install Joint Plate (LANSS600JBLK) connecting both Center Support Mounts (LANSR151) using U-bolts (LAN600UBOLT) and 5/8" serrated flange nuts (LAN690830).
8. Tighten all hardware securing all mounts installed.
9. Attach the stalk roller wings (LANSR038BLK & LANSR039BLK) to the mounts with the pivot pin (LANSR008) and two plastic washers (LANSR009).
10. Secure the pins using 1/2" x 1 3/4" hex bolts (LANFC507), SAE washers (LANFWS55) & 1/2" top lock nuts (RED1F30).
11. Grease the wings.

Figure 7



Figure 8



Figure 6



Kit Installation



Figure 9

Refer to Figures 9 & 10

12. Install the cylinders (LANW250100-S) using the pins that come with them.
13. Ensure that both ends have a port that is facing toward the rear of the tractor, the rod end is attached to the wings and the clevis bolt is oriented upward.
14. When the cylinder is completely extended, the wing frame should be parallel to the ground. Adjust it by screwing the clevis in/out of the rod.
15. If the chains on the roller assemblies are not in the 2nd hole from the top, it is likely they will need to be moved. This can be done now or later when the kit is completed. Simply relieve the chain of tension and move carriage bolt.

Figure 10



Kit Installation

Refer to Figures 11 & 12

16. Hang the roller assemblies from the wings using the U-bolts and remaining flange nuts in the LANSSTFMBH boxes.
17. Slide the roller in or out to cover the track.
18. Make sure that the inner end of the roller is in-line with or outside the hinge pin as shown. (The further out it is the better it will unfold.)



Figure 11

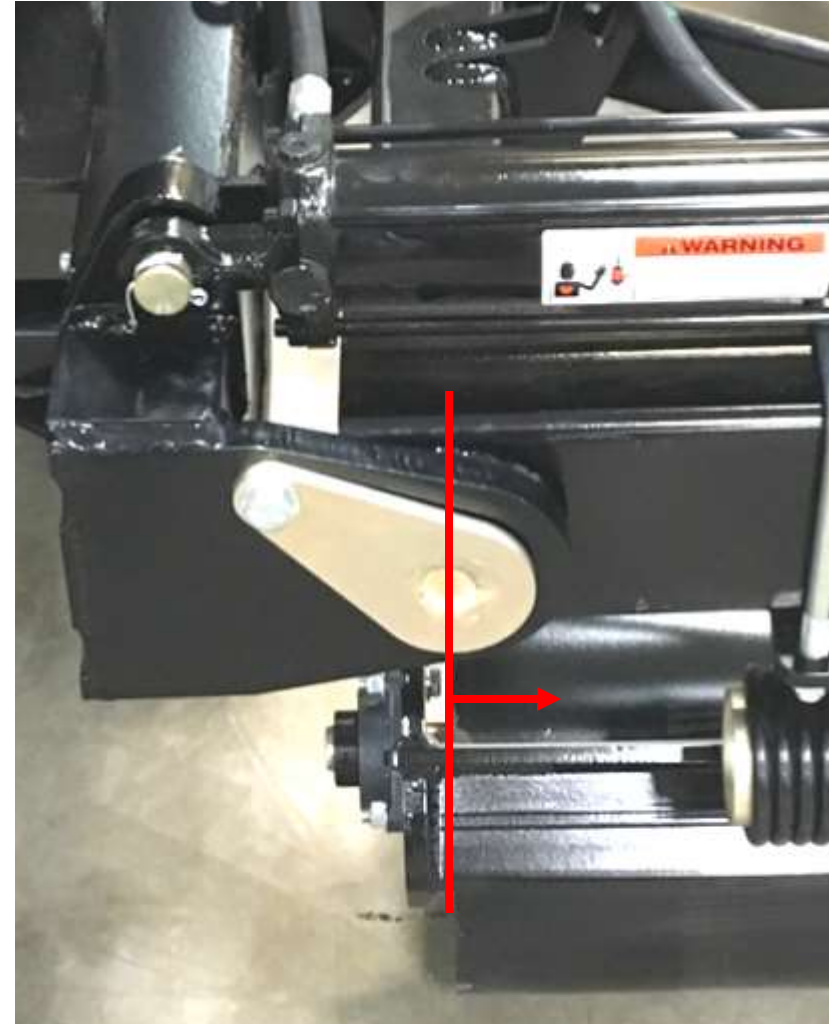
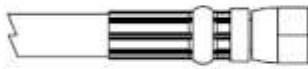

Figure 12

Hydraulic Installation

ITEM NO.	DESCRIPTION	QTY.
1	9/16" MALE JIC TEE	2
2	1/2" FEMALE NPT QUICK COUPLER	2
3	1/2" FEMALE NPT TO 1/2" MALE NPT TEE	2
4	1/2" NPT MALE NIPPLE COUPLING	2
5	9/16" MALE JIC TO 9/16" MALE ORB	2
6	9/16" MALE JIC TO 1/2" MALE NPT	2
7	9/16" MALE JIC TO 9/16" MALE ORB 90 DEG	2
8	9/16" JIC MALE TO FEMALE - 1/32" ORIFICE	2

* 3/8" Diameter Hoses



Every hose end is crimped with a straight swivel flange fitting.

LANSRCATMT8 - Hydraulic Schematic

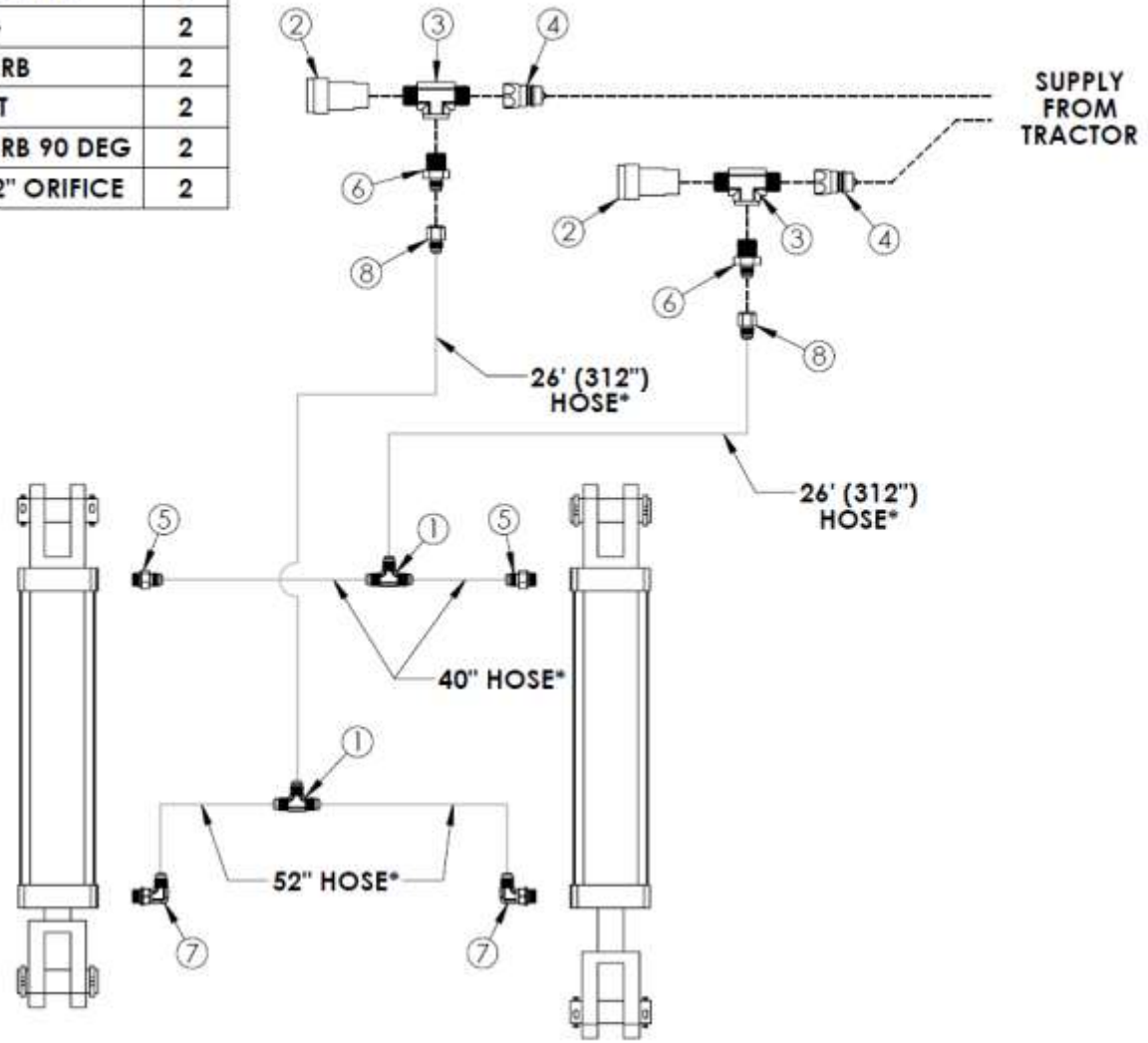

Hydraulic Installation



Refer to Figures 12 - 20

19. Install the hydraulic fittings, found in the hose kit, into the cylinders as shown.
20. Use the 40" and 52" hoses to plumb the cylinders together.
21. Connect the 26' hoses and run them through the tractor as displayed in the figures.
22. Two orifices are included and should be used to slow down the hydraulic fluid, if needed.
23. Constrain the hoses with the provided zip ties.



Hydraulic Installation

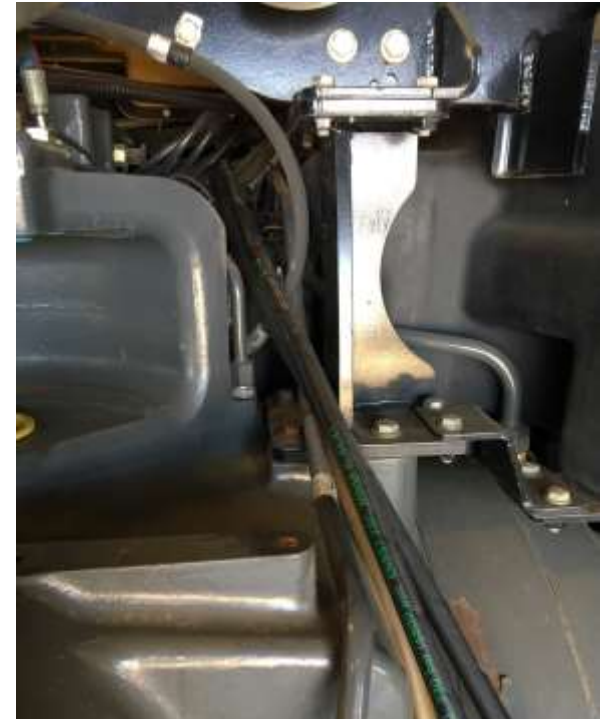

Storage

Refer to Figures 21 & 22

24. 1/2" bent pins (LANSS704) are included in this kit to hold each wing up when storing to prevent the cylinders from settling.
25. To use the pins, push and twist 90 degrees.
26. Use the 1/2" hole in the brackets to store the pins when in use.

Figure 21
Stored



Figure 22
In Use

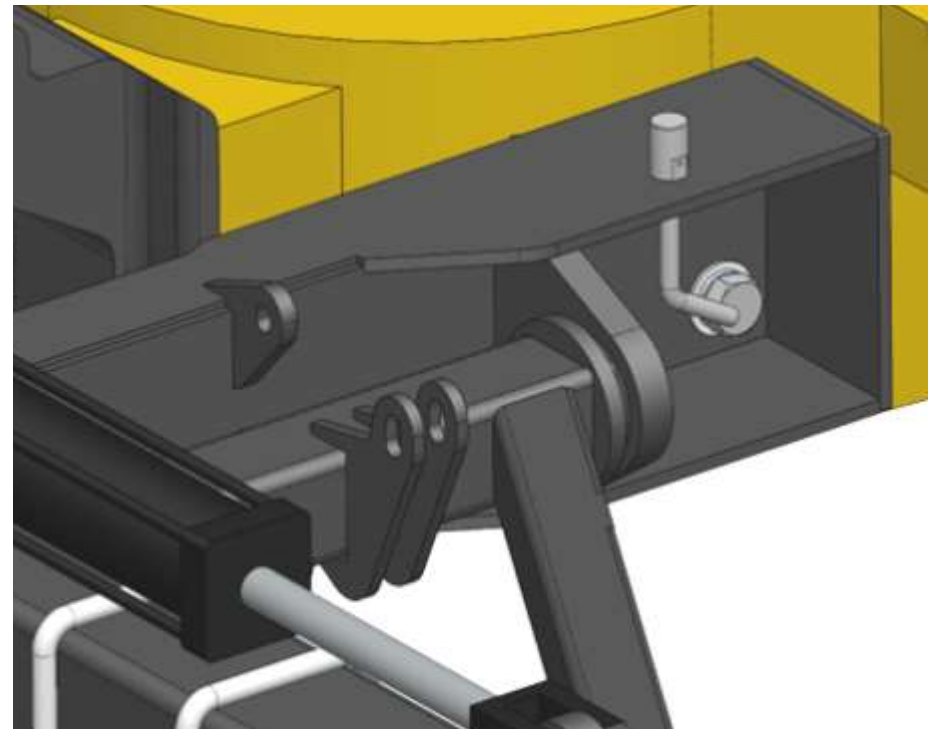

Headlight Clearance Consideration

Refer to Figures A, B & C

If additional light clearance is required, install cylinder stops (LANSCA-1) as necessary (one or two) on each cylinder to hold the roller arms away from the lights.

Note: The cylinder stops will need to be removed in order to utilize the storage pin position (See Figure C).



Figure A

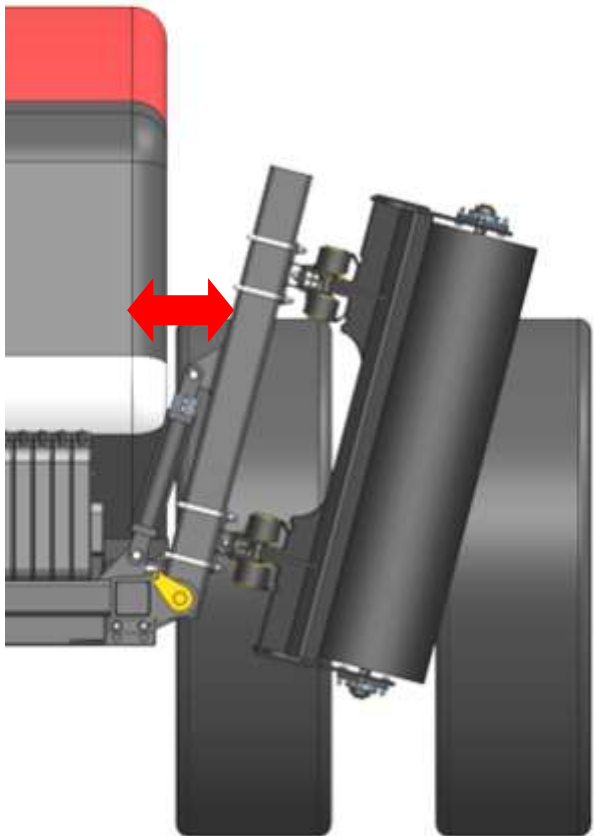

Figure B

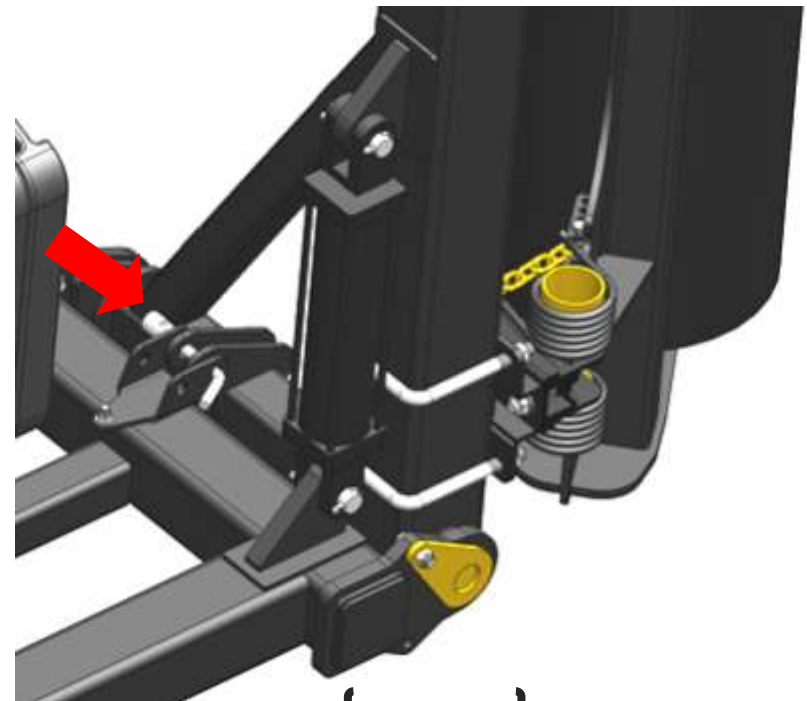

Figure C



For further technical assistance,

Call Lankota Inc. at:

1-866-526-5682