

LANFLAG91565

Installation Instructions

Lankota Unloading Auger Flag Pole and Mount Kit for CIH 17.50" Augers

LANKOTA®

**270 West Park Avenue
Huron, SD 57350
866-526-5682**

Parts

Part Number	Description	Qty
LANAUG1750	Auger Half Band	1
LANFLAG1750	Flag Mount for CIH 17.50" Augers	1
LANFLAG03D-01	Flag Pole—Drilled—2.5' Bottom Piece	1
LANFLAG03D-02	Flag Pole—Drilled—2.5' Top Piece	1
LANFLAG04	Flag Pole Rotating Rings (Pair)	1
LANFLAG07	Flag Pole Connection Tube	1
RED305K	3/8"-16 x 1-1/4" Carriage Head Bolt	2
LAN1618000	3/8"-16 Nylon Lock Nut	2
LANFWS53	3/8" SAE Washer	2
LAN1101	3/16" x 1-1/2" Lynch Pin	1
LAN97526A140	3/16" Domed Rivet—For 1/4" Material	4

Parts

 <p>LANAUG1750 (1)</p>	 <p>LANFLAG1750 (1)</p>	 <p>LANFLAG03D-01 (1)</p>	 <p>LANFLAG03D-02 (1)</p>
 <p>LANFLAG07 (1)</p>	 <p>LANFLAG04 (1 PAIR)</p>	 <p>RED305K (2)</p>	 <p>LAN1618000 (2)</p>
 <p>LANFWS53 (2)</p>	 <p>LAN1101 (1)</p>	 <p>LAN97526A140 (4)</p>	

Installation

NOTE: One portion of the flag pole has two sets of holes - this one is the **BOTTOM (LANFLAG03D-01)**.

Refer to Figures A & B

1. Place the flag pole connection tube (LANFLAG07) inside the bottom flag pole section (LANFLAG03D-01) and attach with two rivets (LAN97526A140) using the holes that are 2.5" in from one end of the flag pole section.
2. Slide the top flag pole section (LANFLAG03D-02) over the connection tube and attach with two rivets.

Figure A

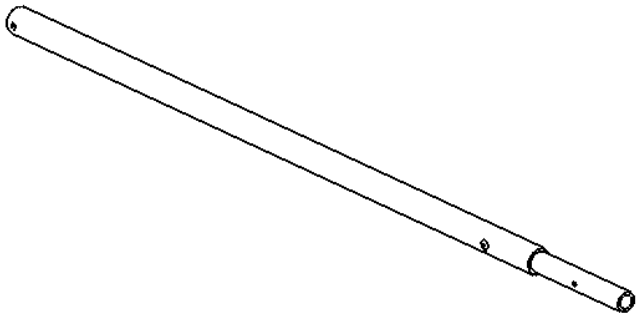
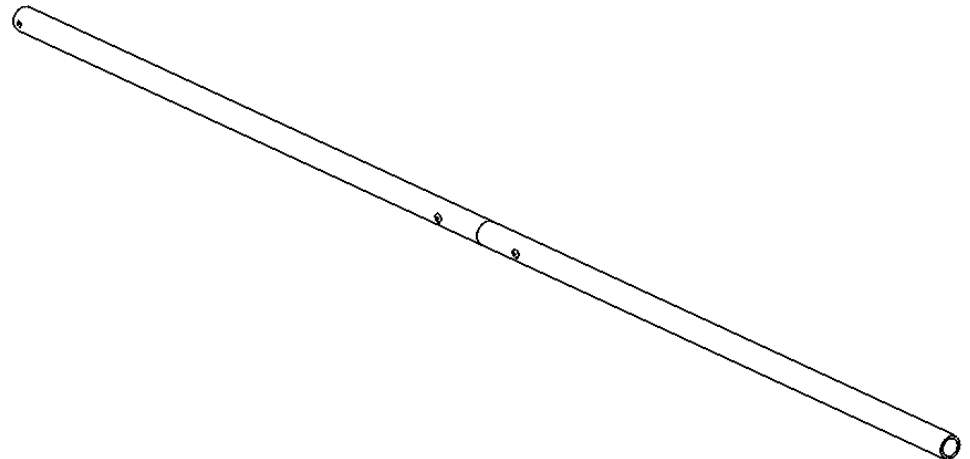

Figure B



Installation

NOTE: There is a hole drilled through one end of the flag pole. This end is the **BOTTOM**.

Refer to Figures 1 & 2

1. Measure the height of your flag. Then install one flag rotating ring onto the flagpole that distance from the top with the rotating ring **TOWARD THE TOP**.
2. Tighten the large set screw to hold the flag mount in place.
3. Loosen the small set screw and unscrew the retaining ring until it lines up with the large set screw. This will provide enough clearance for the rings to properly rotate. Tighten the small set screw.



(Figure 1)



(Figure 2)

Installation

NOTE: There is a hole drilled through one end of the flag pole. This end is the **BOTTOM.**

Refer to Figures 3 & 4

4. Next, install one flag rotating ring onto the top of the flagpole with the rotating ring **TOWARD THE BOTTOM.**
5. Tighten the large set screw to hold the flag mount in place.
6. Loosen the small set screw and unscrew the retaining ring until it lines up with the large set screw. This will provide enough clearance for the rings to properly rotate. Tighten the small set screw.
7. Attach the carabiners to the rotating rings.



Figure 3



Figure 4

Installation

Refer to Figure 5

8. Place the half bands (LANAUG1750 & LANFLAG1750) around the auger tube with the drilled pipe toward the bottom and tighten with the included 3/8"-16 x 1-1/4" Carriage Bolts (RED305K), 3/8" SAE Washers (LANFWS53), and 3/8"-16 Nylon Lock Nuts (LAN1618000).
9. Attach your flag to the carabiners.

Figure 5

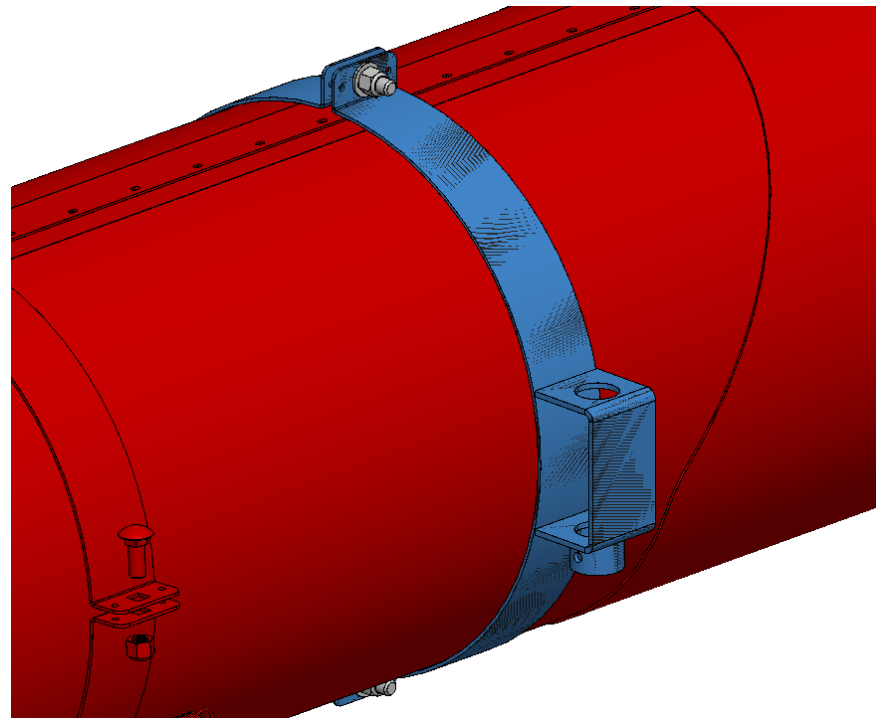

Refer to Figure 6

10. Slip the flag pole into the mount. Retain with the included lynch pin (LAN1101).



Figure 6

For further technical assistance,

Call Lankota Inc. at:

1-866-526-5682