

LANBS62976

Installation Instructions

Lankota Bean Saver Bottom Brush Kit for JD® HD Header

LANKOTA®

270 West Park Avenue

Huron, SD 57350

866-526-5682







Numerical Parts List

Part Numbers	Description	Qty
LANBSHD003	JD HD Bottom Brush Mount	1
LANBSHD004	JD HD Bottom Brush Mount with Shark Fin	1
LANBS6FD35	Bean Saver Brush—37.75"	2
LANBS6FD02-03	Brush Holder - Bottom	2
LANBS6FD02-04	Brush Holder - Top	2
LANFH2CHJ	M8 x 25mm Button Head Torx Screw	6
LAN1133	Flat Washer	6
LANBSBH	Bag of Hardware	2
LANFXG26	5/16" x 3/4" Carriage Bolt	14
REDKRJ8	5/16" Top Lock Nut	14

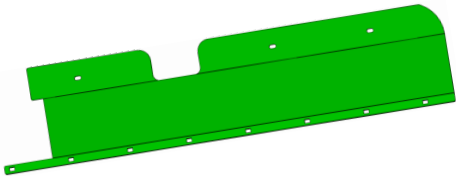
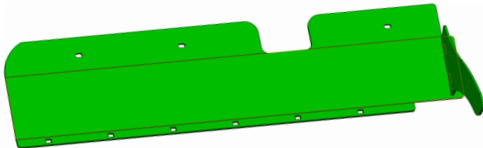
Preparation

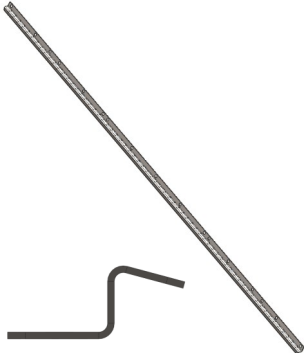
1. Lower the reel and move forward as far as possible.
2. Set the header on the ground or a header trailer.
3. Unhook the head from the combine and back it away.

Pictorial Parts List

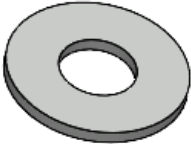
 <p>LANBSHD001 (2)</p>	 <p>LANBSHD002 (1)</p>	 <p>LANBS6FD3775 (2)</p>
 <p>LANBS6FD02-03 (2)</p>	 <p>LANBS6FD02-04 (2)</p>	 <p>LANFH2CHJ (6)</p>
 <p>LANFXG26 (14)</p>	 <p>REDKRJ8 (14)</p>	 <p>LAN1133 (6)</p>

Kit Installation

Refer to Figures 1

1. Take the Brush holders (LANBS6FD02-03 & LANBS6FD02-04) and cut each along the inside etched lines. The finished length should be 35" long (Centered from side to side).

Figure 1

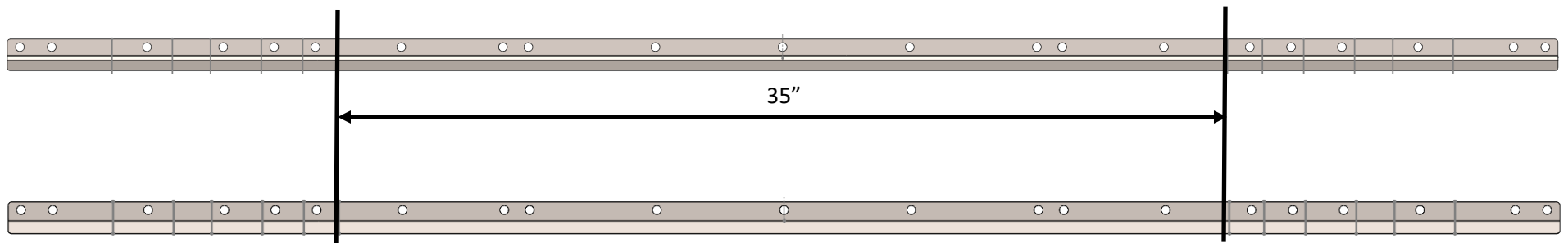

Kit Installation

Refer to Figures 2—5

2. Once Top and Bottom Brush Holders are cut to length, take 5/16" carriage bolts and top lock nuts (LANFXG26 & REDKRJ8) and bolt brush and holders to JD HD Bottom Brush Mounts.
3. Remove factory shark fin & 6 Button head Torx bolts referenced in Figure 4 & 5.

Figure 2

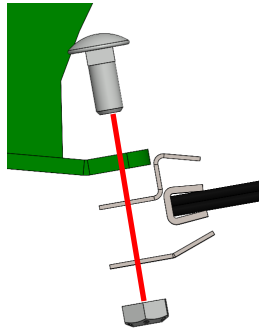

Figure 3



Figure 4

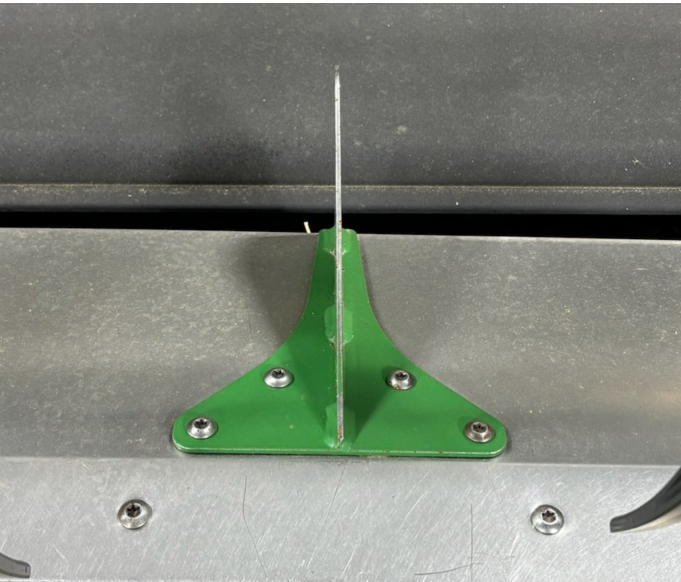
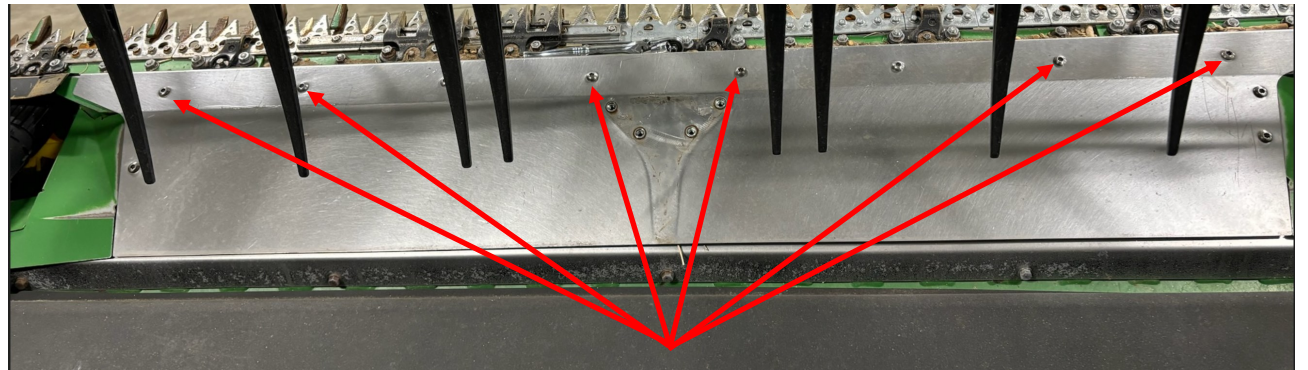

Figure 5



Kit Installation

Refer to Figure 6

4. Center Brush Mount on bottom pan and install provided metric Button Head Torx Screws (LANFH2CHJ) and flat washers (LAN1133) through slotted holes.
5. Tighten Hardware.

Figure 6

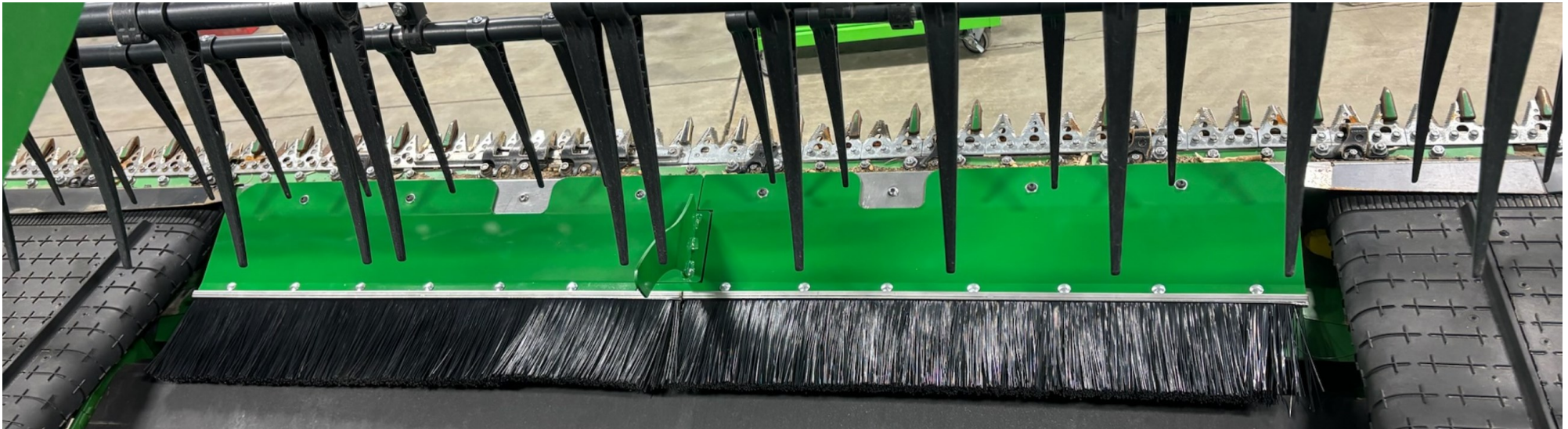



For further technical assistance,

Call Lankota Inc. at:

1-866-526-5682