

LANAB21399

Installation Instructions

Lankota Rear Service Step Kit for JD F4365 & 800R Nutrient Applicator













LANKOTA®

270 West Park Avenue
Huron, SD 57350
866-526-5682

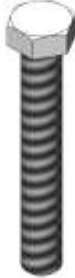
Numerical Parts List

Part Numbers	Description	Qty
LANAB010	Left End Bracket	1
LANAB010M	Right End Bracket	1
LANAB011	Rear Step	2
LANAB012	Center Support Bracket	1
LANAB013	Step Stow Bracket	2
LANAB014	Slow Moving Vehicle Sign Spacer	1
LANCK167	5/16" Steel Knob	2
LAN3718	3/8" Serrated Flange Nut	4
LANFB310	3/8" x 2 1/2" Hex Bolt	2
LANFM7KV	3/8" Serrated Flange Nut	4
LANNAS2	5/16" Serrated Flange Nut	4
LANF216K	5/16" x 4" Carriage Bolt	2
LANFXG26	5/16" x 3/4" Carriage Bolt	2
REDODTT	3/8" Top Lock Nut	2

Pictorial Parts List

				
LANAB010 (1)	LANAB010M (1)	LANAB011 (2)	LANAB012 (1)	LANAB013 (2)
				
LANAB014 (1)	LAN3718 (4)	LANFB310 (2)	LANFM7KV (4)	LANNAS2 (4)
				
LANF216K (2)	LANFXG26 (2)	RED0DTT (2)	LANCK167 (2)	

Kit Installation

Refer to Figures 1 & 2

1. Remove the slow moving vehicle sign on the back of the vehicle and attach the sign spacer (LANAB014) to the back using the existing hardware.
2. Remove the lower two horizontal bolts on the rear bumper on both sides. Save the bolts as they will be reused.



Figure 1



Figure 2

Kit Installation

Refer to Figures 3 - 5

3. Remove the "35 mile/h" sign and attach the center support bracket (LANAB012), with two 3/8" x 1" serrated flange bolts (LANFM7KV) and 3/8" serrated flange nuts (LAN3718). If desired the "35 mile/h" sign can be bolted up with the center support bracket as shown in Figure 3, by first drilling out the square holes with a 3/8" drill bit.
4. Place one of the previously removed bolts in Step 2, through the inside hole on the Left End Bracket (LANAB010).
5. Slide the step (LANAB011) into the large hole on the Left End Bracket.



Figure 3



Figure 4

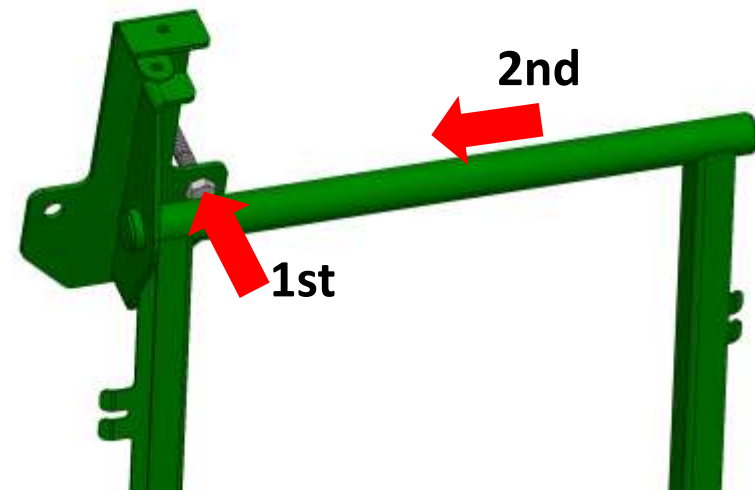

Figure 5

Kit Installation

Refer to Figures 6 & 7

6. While holding the step, left end bracket and bolt together, slide the step into the hole on the side of the center support bracket (LANRB012).
7. Swing the left side of the step and left end bracket in to line up the inside hole on the rear bumper with the bolt. Replace the OEM lock washer and nut on the back side and tighten.
8. Replace and tighten the other bolt on the outside of the left end bracket.
9. Repeat Steps 4—8 on the right side of the machine for the right step.

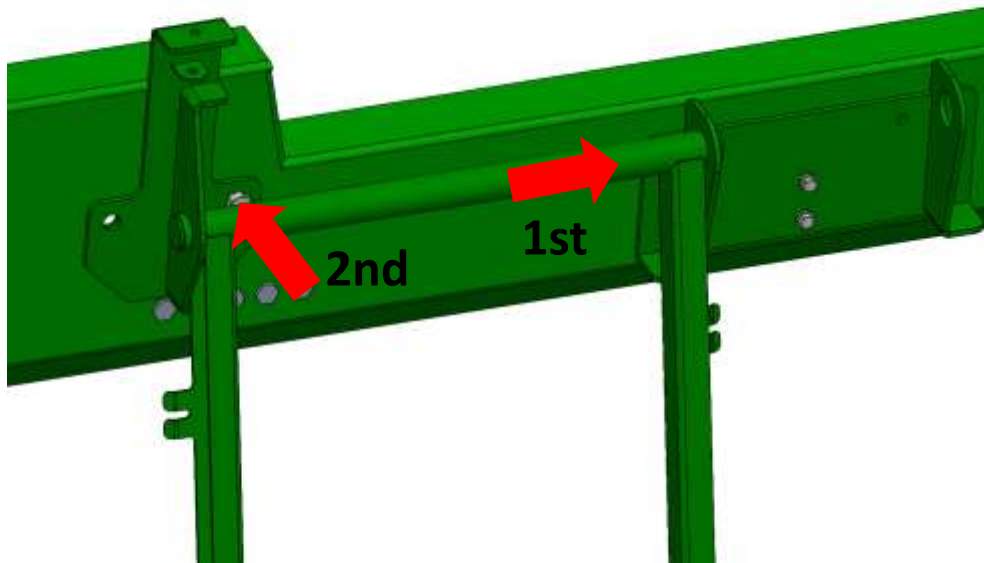

Figure 6



Figure 7

Kit Installation

Refer to Figures 8 - 10

10. Assemble and tighten two sets of the step stow bracket (LANAB013), a 5/16" x 4" carriage bolt (LANF216K), and 5/16" serrated flange nut (LANNAS2).
11. Attach the stow bracket assembly to each end bracket with a 3/8" x 2-1/2" hex bolt (LANFB310) and 3/8" lock nut (REDODTT).
12. Thread a twist knob (LANCK167) on each of the 5/16" x 4" carriage bolts.
13. To stow the step up, swing the stow bracket assembly into the groove on the back side of the step leg and tighten the twist knob.



Figure 8

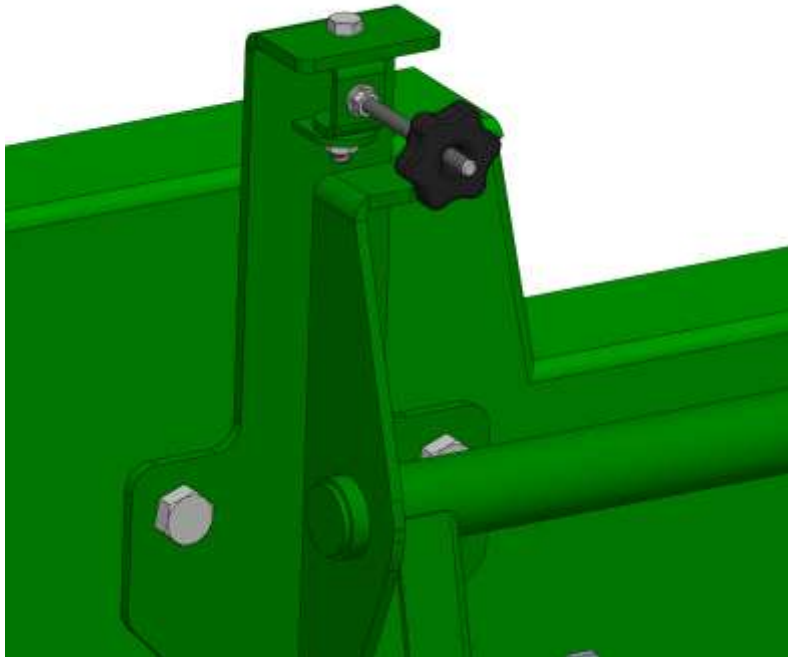

Figure 9



Figure 10

Kit Installation

Refer to Figures 11 & 12

14. At the original location of the slow moving vehicle sign, attach the sign with the sign spacer bracket (LANAB014), two 5/16" x 3/4" carriage bolts, and 5/16" serrated flange nuts (LANNAS2).

For further technical assistance,

Call Lankota Inc. at:

1-866-526-5682



Figure 11



Figure 12