

Lankota, INC.

LAN – 84398

**Cutting Platform Wedge Kit For 600 Series
John Deere Headers
1.5, 3 & 4.5 Degree Angle Addition**

Installation Instructions

LAN – 84398
Parts break down list

 <p>*LAN – 19M7787</p>	 <p>*LAN – H151937</p>	 <p>*LAN – 19M7785</p>
 <p>*LAN – H201028</p>	 <p>*LAN – 14M7298</p>	 <p>*LAN – 19M7866</p>
 <p>LAN - 212896(L) 4.5 DEGREE</p>	 <p>LAN – 212897(R) 4.5 DEGREE</p>	 <p>LAN – 212912(L) 1.5 DEGREE</p>
 <p>LAN – 212913(R) 1.5 DEGREE</p>	 <p>LAN – 212934(L) 3 DEGREE</p>	 <p>LAN - 212935(R) 3 DEGREE</p>
 <p>LAN – 212591 4.5 DEGREE</p>	 <p>LAN – 212589 1.5 DEGREE</p>	 <p>LAN – 212590 3 DEGREE</p>
 <p>LAN – 212685 FACTORY 0 DEGREE</p>	 <p>LAN – 212742 1.5 DEGREE</p>	 <p>LAN – 212743 3 DEGREE</p>



*** Items are included in bag of hardware**

John Deere and JD are registered trademarks of Deere & Company

**REVIEW FIGURES BELOW TO DETERMINE CORRECT
INSTALLATION PROCEDURE FOR YOUR PARTICULAR HEAD:**

IF YOUR LEFT HAND BRACKET LOOKS LIKE:

(A) PERFORM PROCEDURE 1

(B) PERFORM PROCEDURE 2

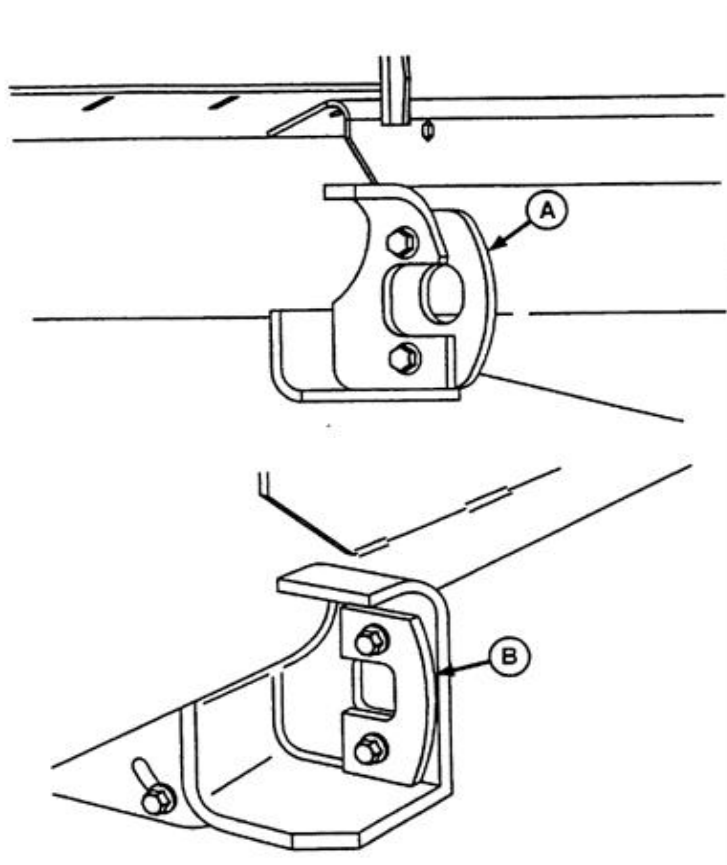

Preparation

Position Combine on level ground with the platform removed.

Determine the Correct Amount of Angle

1. Position the feeder house so it is perpendicular to the ground. Use a level on front surface of feeder house to obtain this, see figure below.
2. Measure from center of spline shaft to the ground as in figure below.

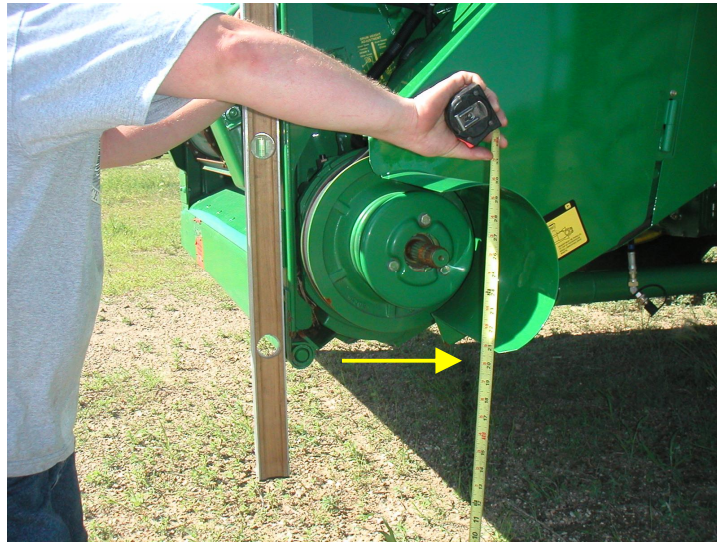

3. From the following table determine correct wedge angle to install.

Table 1

9050 Series STS Combines		9000, 10, & 50 Series CWS Combines	
Figure A	Wedge Angle	Figure A	Wedge Angle
Less than 28"	0	Less than 28"	0
28" – 30.5"	1.5	28" - 29.5"	1.5
30.5" - 32.5"	3	29.5" – 31"	3
More than 32.5"	4.5	More than 31"	4.5

PROCEDURE 1**Installing the Cutting Platform Wedge Kit**

Platform must be removed from combine and placed on header trailer or safely on secure blocks to allow ample room to perform this procedure.

1. Remove both wear plates from header attach brackets by removing the two bolts. (See Figure A) **Right bracket shown.**



Figure A

2. Install new wear bracket selected for your desired angle. Attach using two Bolts (*LAN – 19M7787). Repeat on other side of head. Make sure brackets get attached to inside of mounts. (See Figure B)

Note that Brackets (LAN – 212685) are same as factory 0 degree brackets. These are supplied if customer wishes to change header back to original configuration at a later time.

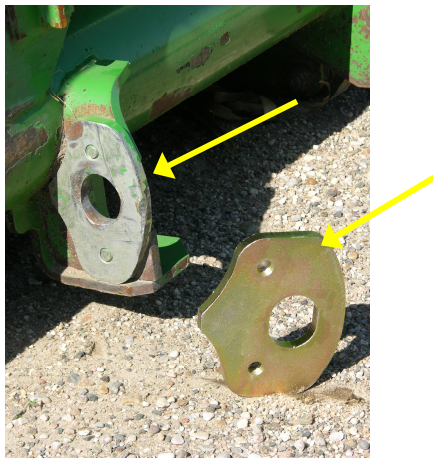

Figure B

3. Measure down from underneath top frame 8 3/4" and mark. Measure out from feeder house opening 7/16" and mark other line. Drill at line crossing using an 11/32" drill bit. Repeat for both sides of head. **On some newer heads, this hole may already exist. See Figure C**



Figure C

2. Mount correct vertical seals for desired angle change to correct bottom seal using one TORX Head Self Tapping Screws (*LAN – H201028) per side. **See Figure D**

RIGHT SIDE SHOWN



Figure D

- Lift into place and install seal assembly through previously drilled holes using Bolt (*LAN19M7866) and Nut (*LAN – 14M7298). Install bolt heads to inside of platform, nuts to seal side. Using the larger bottom wedge piece as a template, mark holes for RIVNUTS as shown below in **Figure E**.

Some newer heads may already have these RIVNUTS installed.



Figure E

- Remove wedge assembly from head completely. Center punch holes at locations marked through template in step above. Drill out holes using a 17/32" drill bit. Tap in 5 RIVNUTS (*LAN – H151937).
- Reinstall seal assembly with two side bolts and nuts from before and attach bottom portion of seal with 5 Bolts (*LAN – 19M7785). Inspect for any gaps around seal that you may lose profitable grain through. Fill gaps with regular black weatherproof caulk.

Now that wedge kit has been installed, it will be necessary to place blocks under the platform just behind the cutter bar at both ends of the cutter bar when removing the head on level ground. Failure to do so will make it extremely difficult to pick up platform next time. Place header on header trailer whenever possible. This action will not be affected by this installation.

END OF PROCEDURE 1

PROCEDURE 2

Installing the Cutting Platform Wedge Kit

Platform must be removed from combine and placed on header trailer or safely on secure blocks to allow ample room to perform this procedure.

1. Remove both wear plates from header attach brackets by removing the two bolts. (See **Figure A**)



Figure A

2. Measure out from vertical bracket 10 mm and mark a line parallel to bracket as shown in **Figure B**. **Bottom flat bracket is not removed!** Remove vertical bracket from main frame tube using a cutting torch. Be certain to not cut into main frame tube as this could weaken the tube. Grind all surfaces smooth.

- Place outside edge of new Bracket LAN – 212679(R) & LAN – 212678(L) on mark made in step above. Weld new bracket to main frame tube and bottom flat bracket making sure to only weld on out side of brackets at all connecting points. Do not weld on inside of brackets as this may interfere with mounting of wear plates. Paint brackets when welds cool for a proper finishing.



Figure B

- Install new wear bracket selected for your desired angle. Attach using two Bolts (*LAN – 19M7787). Repeat on other side of head. Make sure brackets get attached to inside of mounts. See Figure C.

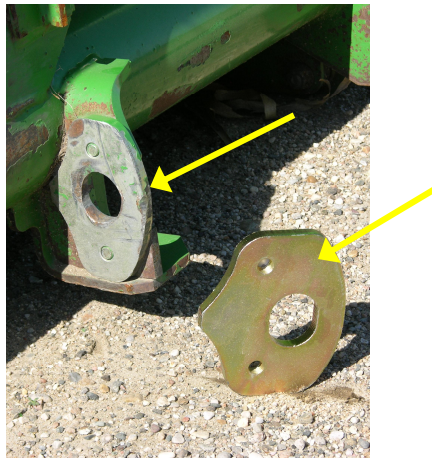

Figure C

5. Measure down from underneath top frame 8 3/4" and mark. Measure out from feeder house opening 7/16" and mark other line. Drill at line crossing using an 11/32" drill bit. Repeat for both sides of head. On some newer heads, this hole may already exist. **See Figure D.**



Figure D

6. Mount correct vertical seals for desired angle change to correct bottom seal using one TORX Head Self Tapping Screw (*LAN – H201028) per side. **See Figure E.**

RIGHT SIDE SHOWN



Figure E

7. Lift into place and Install seal assembly through previously drilled holes using Bolt (*LAN19M7866) and Nut (*LAN – 14M7298). Install bolt heads to inside of platform, nuts to seal side. Using the larger bottom wedge piece as a template, mark holes for RIVNUTS as shown below in **Figure F**.

Some newer heads may already have these RIVNUTS installed.

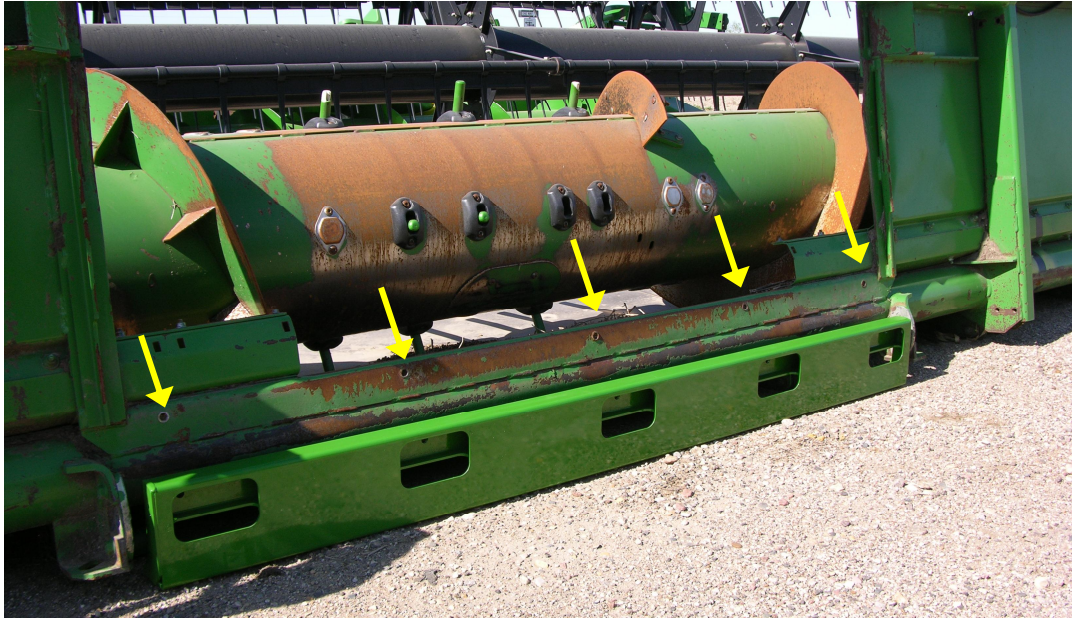

Figure F

8. Remove wedge assembly from head completely. Center punch holes at locations marked through template in step above. Drill out holes using a 17/32" drill bit. Tap in 5 RIVNUTS (*LAN – H151937).
9. Reinstall seal assembly with two side bolts and nuts from before and attach bottom portion of seal with 5 Bolts (*LAN – 19M7785). Inspect for any gaps around seal that you may lose profitable grain through. Fill gaps with regular black weatherproof caulk.

Now that wedge kit has been installed, it will be necessary to place blocks under the platform just behind the cutter bar at both ends of the cutter bar when removing the head on level ground. Failure to do so will make it extremely difficult to pick up platform next time. Place header on header trailer whenever possible. This action will not be affected by this installation.

For further technical information you may contact:

**Lankota Inc
(866) 526-5682**