

# LANRB18222

## Installation Instructions

Lankota Net Wrap Assist for John Deere Balers

(560R, 460R, 460M, 560M, 569, 469, 568, 468, 567, 467, 566, 450M, 450E, 559, 459, 558, 557, 556, 458, 457)

# LANKOTA®

270 West Park Avenue  
Huron, SD 57350  
866-526-5682

# Numerical Parts List

<b>Part Numbers</b>	<b>Description</b>	<b>Qty</b>
LANRB001	Winch Housing	1
LANRB003	Winch Housing Cover	1
LANRB004	Net Wrap Lifting Hook	1
LANRB008	Magnet Plate	1
LANRB009	Hinge Backer Plate	1
LANRB012	Door Assembly	1
LANRB014	Roller Arm - 5' Diameter Baler	1
LANRB015	Roller Arm - 6' Diameter Baler	1
LANMCHN40	1.5" Magnet	3
LANBBSIGN	Slow Moving Vehicle Sign	1
LANAH161580	Snap Over Latch	2
LANRBWH1	Wiring Harness - Tractor Battery to Rear of Tractor	1
LANRBWH2	Wiring Harness - Winch to Front of Baler	1
LANRBWH3	Wiring Harness - Winch Relay to Winch	1
LAN101025	Warn VRX-25 Winch	1
<b>LANRB18222BH</b>	<b>Box of Hardware</b>	<b>1</b>
Each Bag Includes:		
LAN8863T28	Loop Clamp	3
LANF90631A007	#6 Nyloc Nut	5
LANF92210A148	#6 Flat Head Screw	5
LANF06WS	#10 Socket Head Screw	2
LANF92949A537	1/4" Socket Head Screw	2
LAN9657K21	3" Compression Spring	1
LAN9600K321	Push-in Grommet	2

# Numerical Parts List

Part Numbers	Description	Qty
<b>LANRB18222BH Continued...</b>		
Each Bag Includes:		
LAN14M7298	M8 Flange Nut	1
LAN1133	5/16" Flat Washer	4
LAN18A	3/8" x 1" Carriage Bolt	3
LAN3718	3/8" Serr Flange Nut	7
LANB203	5/16" x 3/4" Hex Bolt	4
LANEJRN	1/4" Nyloc Nut	2
LANFODNU	#10 Nyloc Nut	5
LANFH1H2M	#10 Flat Head Screw	3
LANFK303	3/8" x 3/4" Carriage Bolt	2
REDWU51	1/4" Flat Washer	2
LAN44302	Zip Tie	12
LANFHB400	4" Hole Saw	1
LANFM7KV	3/8" x 1" Serr Flange Bolt	5
LAN1618000	3/8" Nyloc Nut	2
LAN18000	3/8" Flat Washer	6
LAN18A00	3/8 x 1" Bolt	2
LANFOEL2	#10 SAE Flat Washer	3
LAN32809	5/16" Ring Terminal	1
LANPRVW	1/4" x 3/4" Thread Forming Bolt	1

**Attention:** Some winch vendor hardware provided in winch box will be used but is not listed above.  
**Note:** Not all winch vendor hardware will be used.

# Pictorial Parts List

					
LANRB001 (1)	LANRB003 (1)	LANRB004 (1)	LANRB008 (1)	LANRB009 (1)	LANRB012 (1)
					
LANRB014 (1)	LANRB015 (1)	LANMCHN40 (3)	LANBBSIGN (1)	LANAH161580 (2)	LANRBWH1 (1)
			START OF HARDWARE BAG		
LANRBWH2 (1)	LANRBWH3 (1)	LAN101025 (1)	START OF HARDWARE BAG	LAN8863T28 (3)	LANF90631A007 (5)
					
LANF92210A148 (5)	LANF06WS (2)	LANF92949A537 (2)	LAN9657K21 (1)	LAN9600K321 (2)	LAN14M7298 (1)

# Pictorial Parts List

					
LAN1133 (4)	LAN18A (4)	LAN3718 (7)	LANB203 (4)	LANEJRN (2)	LANF0DNU (5)
					
LANFH1H2M (3)	LANFK303 (4)	REDWU51 (2)	LAN44302 (12)	LANFHB400 (1)	LANFM7KV (5)
					
LAN1618000 (2)	LAN18000 (6)	LAN18A00 (2)	LANF0EL2 (3)	LAN3208 (1)	LANPRVW (1)

# Winch Assembly

## Refer to Figures 1 - 2

1. Attach the blue wire to the blue winch post and the yellow wire to the yellow winch post (LANRBWH3). Use the nuts provided in the winch hardware bag (P/N: 100666). Route wires as shown in Figure 1.
2. Attach the winch to the main enclosure (LANRB001) as shown, with the cable spooling off the top of the drum, using the M8 X 20 bolts and lock washers provided in the winch hardware bag (P/N: 100666).



Figure 1

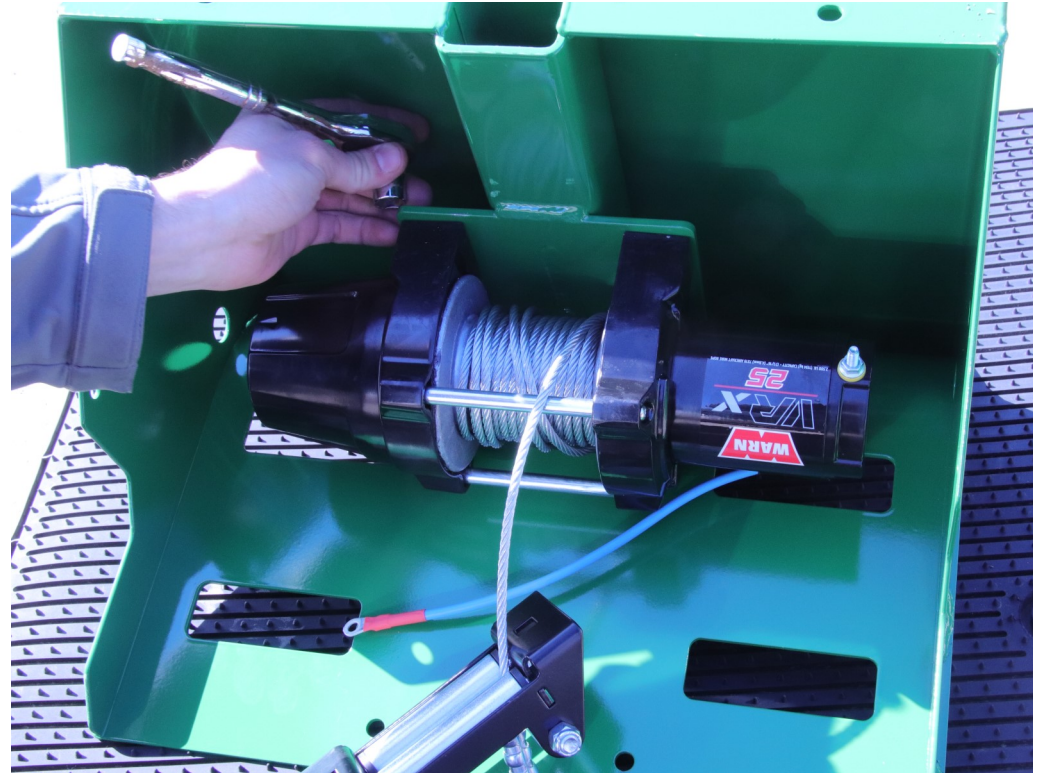

Figure 2

# Winch Assembly

Refer to Figures 3 - 4

3. Slide the roller tube (LANRB014 - 5' diameter baler or LANRB015 - 6' diameter baler) into the tube on main enclosure (LANRB001).

## 5' Diameter Baler Model Examples

450M	550M
450R	559
450E	459
457	557

## 6' Diameter Baler Model Examples

560R	560M
569	568
567	566



Figure 3



Figure 4

# Winch Assembly

## Refer to Figures 5 - 7

4. Attach the roller tube to the main enclosure using a 3/8" x 3/4" carriage bolt (LANFK303) and 3/8" serrated flange nut (LAN3718) on each side (See Figure 5).
5. *NOTE: To get slack in the cable, free spool the winch drum with hub lock on the left side of the winch. Be sure to re-lock the hub before operation.* Attach the cable guide roller (provided with the winch) to the roller arm using a 3/8" washer (LAN18000) under the head of a 3/8" x 1" bolt (LAN18A00) with a 3/8" serrated flange nut (LAN3718) on the top. Do this on each side.

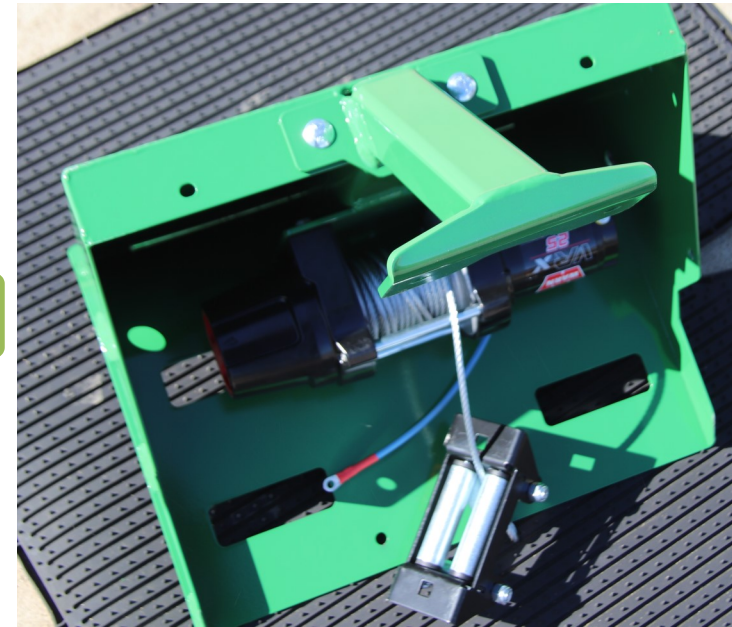

Figure 5



Figure 6



Figure 7



# Winch Assembly

## Refer to Figures 8 - 9

- Slide the spring (LAN9657K21) over the loop at the end of the cable.
- Remove the cotter pin and pin from the hook. Attach the hook to the cable with pin, cotter pin AND a 3/8" washer (LAN18000) on both sides of the cable.

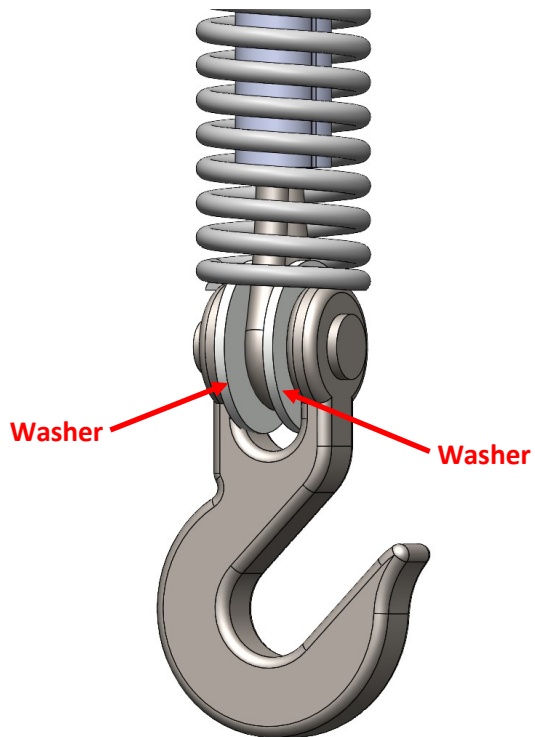

Figure 8



Figure 9

# Wiring Installation

## Refer to Figures 10 - 11

8. Mount the winch relay to the inside of the main enclosure (LANRB001), as shown in Figure 10, with two bolts, washers and lock nuts included in the winch hardware bag (P/N: 74539, wrench size: 8 mm).
9. Attach plate LANRB008 to the winch switch using the two small screws provided in the winch hardware bag (P/N: 74373).
10. Starting at the rocker switch, slide the slit loom over cable the entire length.



Figure 10



Figure 11

# Wiring Installation

## Refer to Figures 12 - 14

11. Install a rubber grommet (LAN9600K321) over the end of the winch switch cable.
12. Install a rubber grommet over both the eye terminals of the wiring harness (LANRBWH2) and the eye terminal of the 4' black grounding wire as shown in Figure 14.
13. Route the winch switch cable in through the hole in the left side of the main enclosure (LANRB001), behind the square tube, and over to the winch relay.
14. Route the eye terminals on LANRBWH2 and 4' black grounding wire in through the hole in the right side of the main enclosure as shown in Figure 14.
15. Using a flat screw driver, carefully work around the rubber grommet, tucking the inside lip into the main enclosure. See Figure 14.



Figure 14

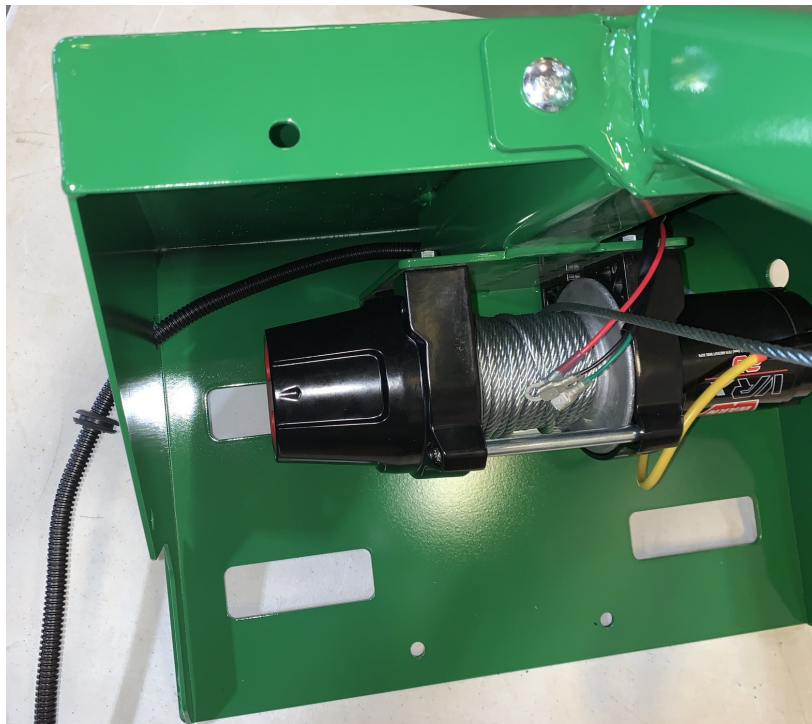

Figure 12



Figure 13

# Wiring Installation

Refer to Figures 15 - 16

For the following steps, use hardware provided in the winch hardware bag (P/N: 100668).

16. Wire the winch relay as shown. **NOTE: Do not over tighten the nuts on the relay posts as this can cause damage to the relay.**
17. The ignition power wire for the winch switch (shown with a red arrow in Figure 15) must be wired to the red stud on the winch relay, with the red wire from harness LANRBWH2 (shown in Figure 16).
18. The brown jumper wire must be wired to the black relay stud with the black wire from harness LANRBWH2 and the 4' black wire (shown in Figure 16).
19. Use LANRBWH3 to connect the yellow winch stud to the yellow relay stud and the blue winch stud to the blue relay stud.
20. Ensure all nuts on the relay are secure and black rubber boots from the winch hardware bag (P/N:74543) are installed over the terminal ends.

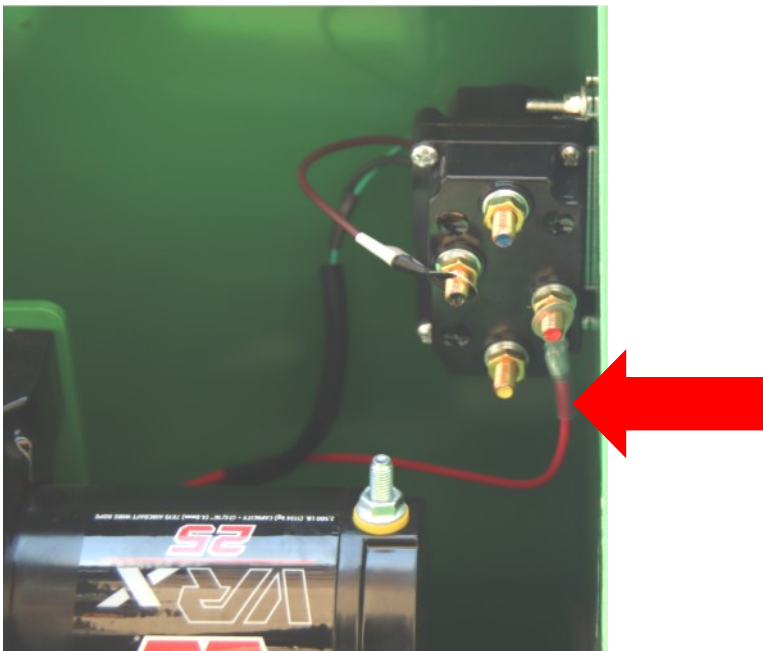

Figure 15



Figure 16

# Winch Enclosure Installation

## Refer to Figures 17 - 19

21. If present, remove the slow moving vehicle sign and the three center bolts from top, rear baler bracket in the center of the baler (shown with red circles). If there are no bolts/belt dividers present, GO TO STEP 23.
22. Using 3/8" x 1" carriage bolts (LAN18A) and 3/8" serrated flange nuts (LAN3718), mount the winch assembly while re-attaching the belt dividers. Tighten bolts. GO TO STEP 24.
23. Mount the winch assembly using three 3/8" x 1" serrated flange bolts (LANFM7KV) and 3/8" serrated flange nuts (LAN3718) with the head of the bolts facing the baler belts. Tighten bolts.

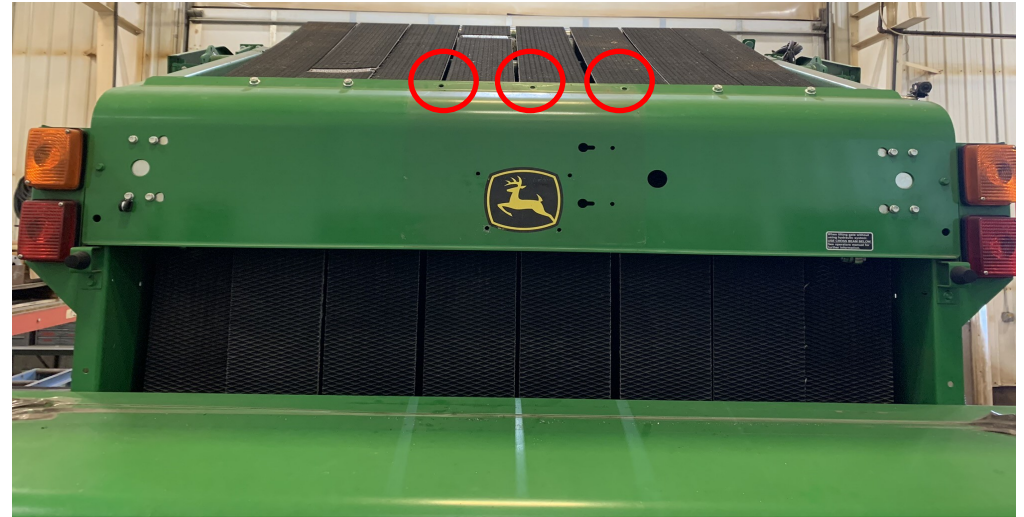

Figure 17



Figure 18

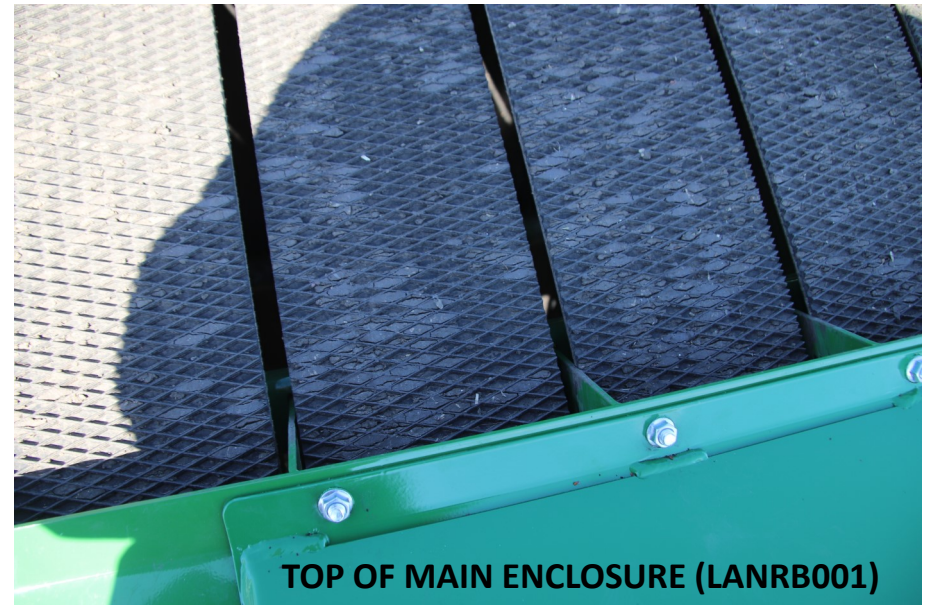

Figure 19

# Winch Enclosure Installation

## Refer to Figures 20 - 22

24. Using a 3/8" drill bit, drill through the holes in the main enclosure (LANRB001) and through the back of the baler.
25. With the head of the bolts facing the baler belts, bolt the main enclosure (LANRB001) to the baler with two 3/8" serrated flange bolts (LANFM7KV), 3/8" washers (LAN18000), and 3/8" nyloc nuts (LAN1618000). Tighten all bolts.
26. Install the enclosure cover (LANRB003) with four 5/16" washers (LAN1133) and 5/16" X 3/4" bolts (LANB203). Tighten all bolts.



Figure 21



Figure 20



Figure 22

# Rocker Switch Installation

## Refer to Figures 23 - 24

27. Route the winch switch cord across the back of the baler to the left securing it with a loop clamp (LAN8863T28).
28. Secure the winch switch cord with a loop clamp on the available stud with an M8 flange nut (LAN14M7296) just below the top of the net wrap door (shown with a red arrow).



Figure 23

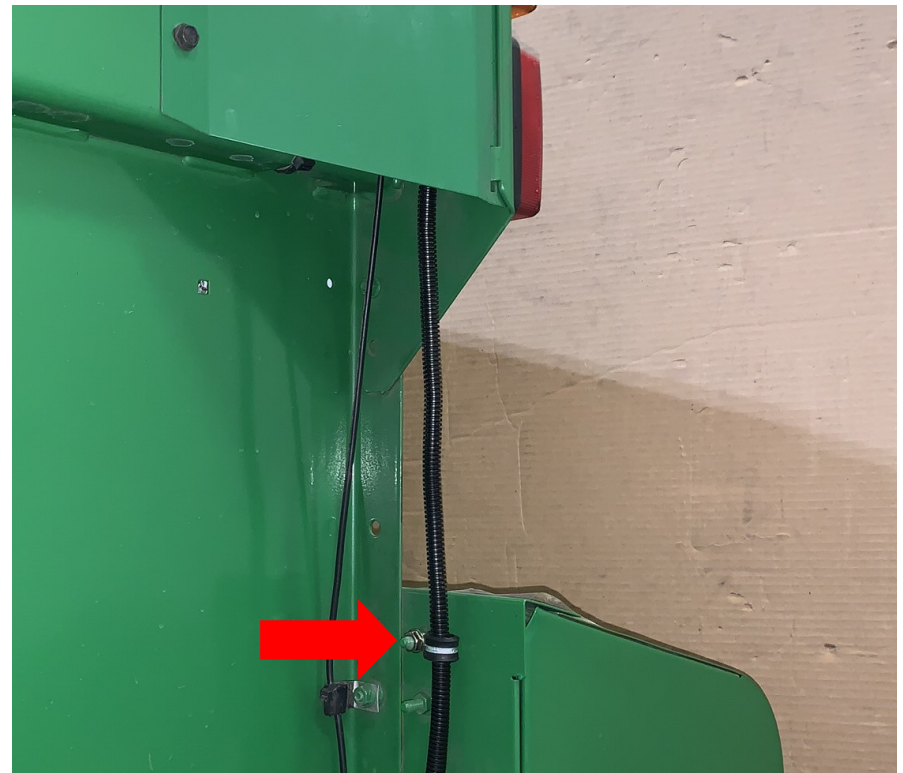

Figure 24

# Rocker Switch Installation

Refer to Figures 25 - 27

29. When facing the net wrap door, go to the left hand side.
30. Using a 1/4" drill bit, measure down from the top of the net wrap door and drill holes at 3" and 16.5". Drill 1/2" in from the side of the net wrap door.



Figure 26

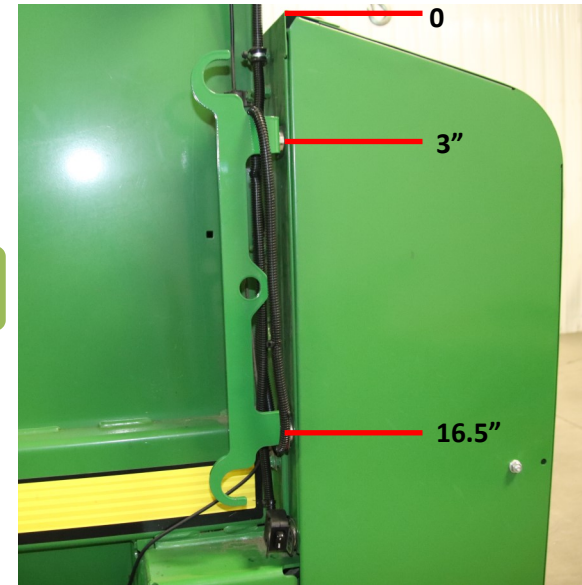

Figure 25



Figure 27



# Rocker Switch Installation

## Refer to Figures 28 - 29

31. Using #10 x 1" bolts (LANFH1H2M), #10 SAE washers (LANF0EL2) and #10 nyloc nuts (LANF0DNU), attach magnets (LANMCHN40) in the previously drilled holes. **DO NOT OVER TIGHTEN**. The magnets will be used to hold the lifting hook (LANRB004) during storage.

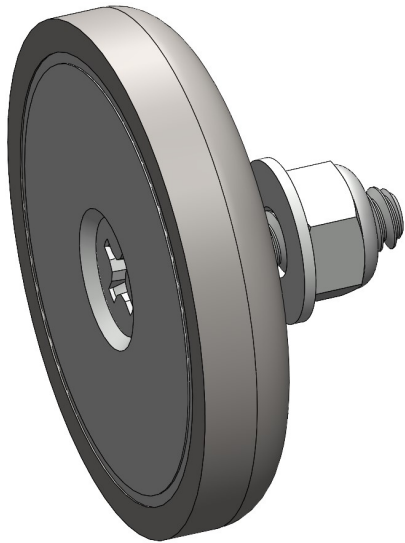

Figure 28



Figure 29

# Rocker Switch Installation

## Refer to Figures 30 - 31

32. Put the net wrap hook (LANRB004) on the previously installed magnets. Coil the winch switch cord around the net wrap hook with the switch hanging below.
33. Temporarily place the last magnet (LANMCHN40) on the baler and let the switch snap to the magnet.
34. Mark the center hole of the magnet in the desired location which keeps the switch cord tight, drill a hole and attach the magnet. **DO NOT OVER TIGHTEN.**



Figure 30



Figure 31

# Hinged Cover Installation - Access Door (Plastic Net Wrap Door)

Refer to Figures 32 - 33

**NOTE: This page for balers with a plastic net wrap door.**

35. Open the net wrap door and measure forward from the cross tube above the latch and mark at 2 1/4" and 5 1/4". **Be sure you are in the center of the net wrap door.**
36. Drill a 4" hole at each of the marks with the hole saw provided (LANFHB400). This can be done by drilling the pilot hole on the inside, then closing the net wrap door and finishing the holes from the outside.



Figure 32



Figure 33

# Hinged Cover Installation - Access Door (Plastic Net Wrap Door)

Refer to Figures 34 - 35

**NOTE: This page for balers with a plastic net wrap door.**

37. Hold the hinged cover (LANRB012), centered on the net wrap door, and the bottom flush with the bottom of the raised section on the net wrap door. With the hinge on LANRB012 laying flat on the net wrap door, mark through the five hinge holes.

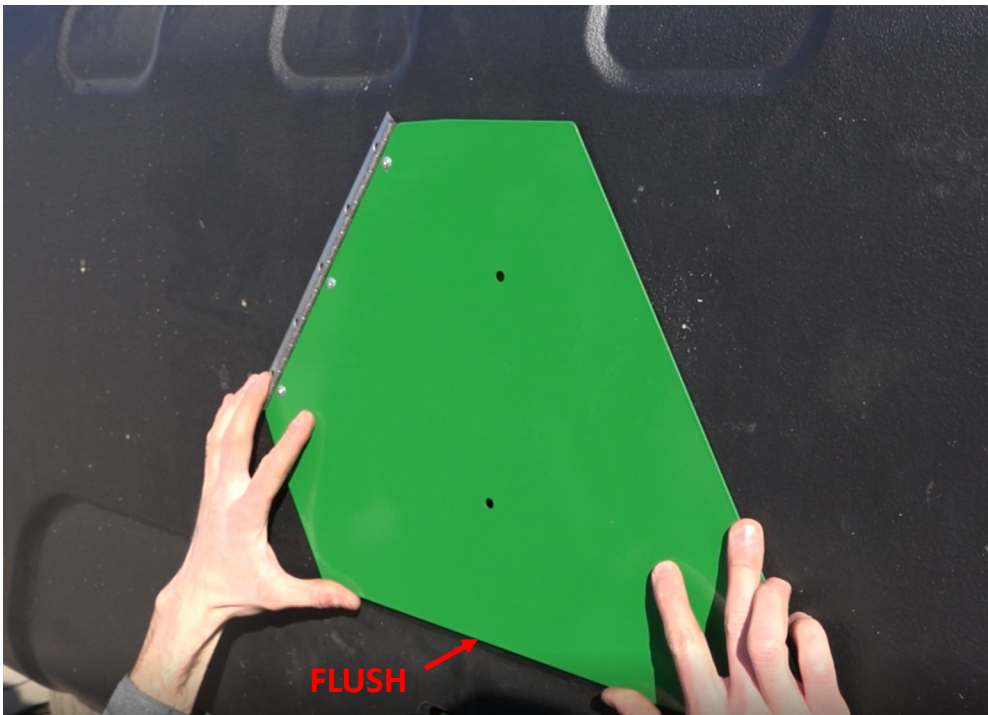

Figure 34



Figure 35

# Hinged Cover Installation - Access Door (Metal Net Wrap Door)

Refer to Figures 36 - 37

**NOTE: This page for balers with a metal net wrap door.**

35. From the base of the net wrap door handle, measure up and mark at 5 1/2" and 8 1/2". **Be sure you are in the center of the net wrap door.**
36. Drill a 4" hole at each of the marks with the hole saw provided (LANFHB400).
37. Hold the hinged cover (LANRB012) directly over the slow moving vehicle decal on the net wrap door while lining up the bottom and right edge. With the hinge on LANRB012 laying flat on the net wrap door, mark through the five hinge holes.



Figure 37

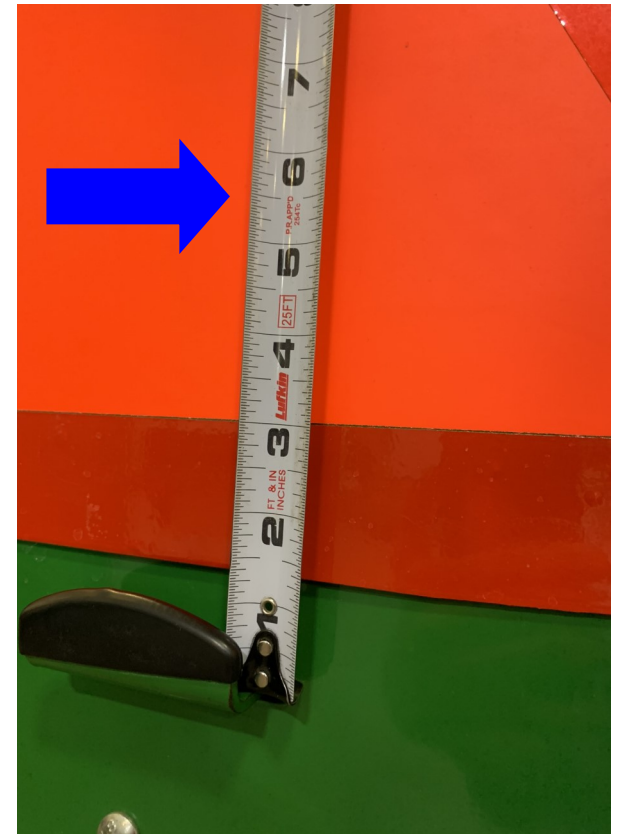

Figure 36

# Hinged Cover Installation - Access Door (Universal)

## Refer to Figures 38 - 39

38. Using a 3/16" drill bit, drill through the five marks on the net wrap door for the hinged cover (LANRB012).
39. Using a cut off grinder, sawzall, etc. cut off the triangle sections, left by drilling the two holes, in order to make a slot (cut lines in red).



Figure 38



Figure 39

# Hinged Cover Installation - Access Door (Universal)

## Refer to Figures 40 - 42

40. Attach the hinged cover (LANRB012) to the net wrap door with five bolts (LANF92210A148) and nuts (LANF90631A007). Use the washer strip (LANRB009) under the nuts on the inside of the door shown in Figure 41.
41. Drill clearance holes in the net wrap door for the back side of the rivets (shown with white circles in Figure 42). **Note: This will allow the hinged cover to close completely and the hinge fasteners to be tightened correctly.**
42. Check that hinge fasteners are tight.



Figure 40



Figure 41



Figure 42

# Hinged Cover Installation

## Refer to Figures 43 - 45

43. With Hinged Door (LANRB012) flipped down (closed), temporarily place Snap Clip (LANAH161580) in bottom right hand area as shown. Mark center hole of snap clip.
44. With Hinged Door (LANRB012) flipped up (open), temporarily place Snap Clip (LANAH161580) in top right hand area as shown. Mark center hole of snap clip.
45. Drill at these two locations with a 1/4" drill bit and attach the snap clips with one screw (LANF92949A242), washer (REDWU51) and nut (LANFODNU) per snap clip.
46. Attach the slow moving vehicle sign to LANRB012 with two screws (LANF92949A537) and nuts (LANEJRN).

Figure 43

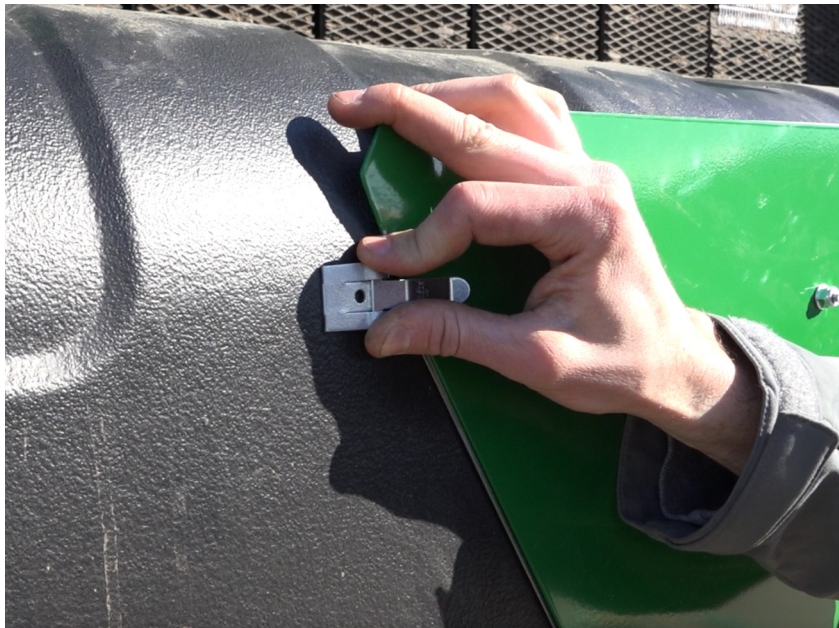
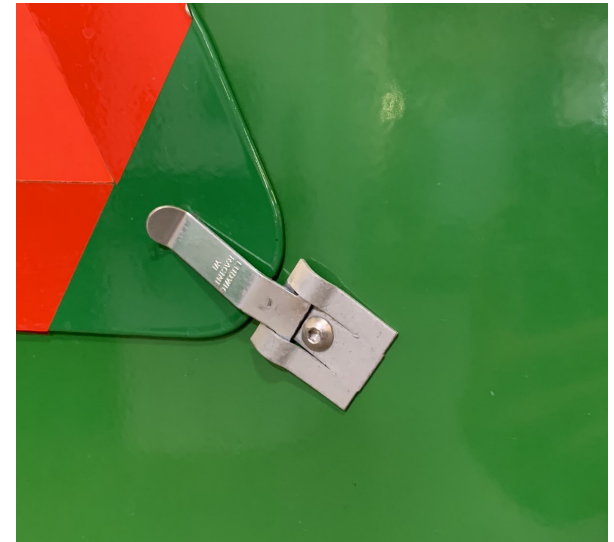

Figure 44

Figure 45





# Wiring Harness Routing

## Refer to Figures 46 - 47

47. Route wiring harness LANRBWH2 and the 4' black grounding wire from the winch assembly across the back of the baler to the right securing it with a loop clamp (LAN8863T28) as shown in Figure 46.
48. Remove the factory bolt to expose the hole shown with a red arrow in Figure 46. **Note: If this bolt is not present, skip STEPS 49 & 50, and attach the eye terminal of the black grounding wire to a desired location on the baler. Attach by drilling a 3/16" hole and use the 1/4" thread forming bolt (LANPRVW).**
49. Cut the 4' black wire with enough length to reach behind to the hole on the back side of the light bracket. Strip the insulation back approximately 1/4" on the end of the black wire. Crimp and heat the 5/16" ring terminal (LAN3208) onto the black wire.
50. Re-install the bolt to attach the ring terminal to the back side of the light bracket (shown in Figure 47).

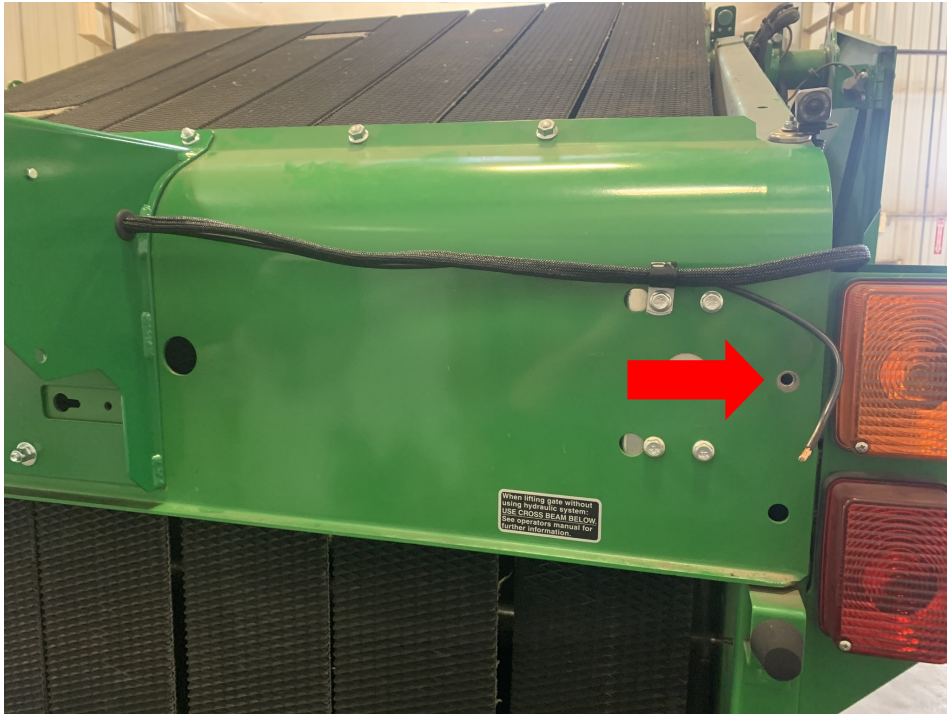

Figure 46



Figure 47

# Wiring Harness Routing

## Refer to Figures 48 - 51

51. Route the wiring harness (LANRBWH2) as shown, over the door pivot, under the side and front covers and down the baler tongue following the factory hoses and wiring.
52. Pull the wiring harness down the tongue to the desired length. Coil the excess length under the side door if necessary and secure the entire harness with zip ties.
53. Starting at the rear of the tractor with the connector end of LANRBWH1 at the desired location, route the wiring harness to the tractor battery and connect the ring terminals to the battery. Ensure the wiring harness is secured and clear of sharp or rotating components along the entire length. **Note: Extra tractor harnesses are available if operator uses multiple tractors to operate baler with Net Wrap Loader installed.**



Figure 48



Figure 49



Figure 50



Figure 51



For further technical assistance,  
Call Lankota Inc. at:  
**1-866-526-5682**

